



AVX
A KYOCERA GROUP COMPANY

AVX
Transient Suppression Products

The contents of this catalog are entitled and located on the pages noted below:

TransGuard Product Overview	1
Part Number Identification	2
Available TransGuard Ratings	3
Dimensions	5
TransGuard Electrical Performance Characteristics	6
Medium Power Multilayer Chip Varistors	11
StaticGuard	19
MultiGuard	21
AntennaGuard	25
USB Series Varistors	29
CAN BUS Varistors	33
UltraGuard	35
TransFeed and TransFeed Array	38
TransGuard Typical Circuits Requiring Protection	46
TransGuard Application Notes	52
Packaging - Chips	68
Packaging - Axial Leads	72

NOTICE: Specifications are subject to change without notice. Contact your nearest AVX Sales Office for the latest specifications. All statements, information and data given herein are believed to be accurate and reliable, but are presented without guarantee, warranty, or responsibility of any kind, expressed or implied. Statements or suggestions concerning possible use of our products are made without representation or warranty that any such use is free of patent infringement and are not recommendations to infringe any patent. The user should not assume that all safety measures are indicated or that other measures may not be required. Specifications are typical and may not apply to all applications.

GENERAL DESCRIPTION

The AVX TransGuard® Transient Voltage Suppressors (TVS) with unique high-energy multilayer construction represents state-of-the-art overvoltage circuit protection. Monolithic multilayer construction provides protection from voltage transients caused by ESD, lightning, NEMP, inductive switching, etc. True surface mount product is provided in EIA industry standard packages. Thru-hole components are supplied as conformally coated axial devices.

TRANSQUARD® DESCRIPTION

TransGuard® products are zinc oxide (ZnO) based ceramic semiconductor devices with non-linear voltage-current characteristics (bi-directional) similar to back-to-back zener diodes. They have the added advantage of greater current and energy handling capabilities as well as EMI/RFI attenuation. Devices are fabricated by a ceramic sintering process that yields a structure of conductive ZnO grains surrounded by electrically insulating barriers, creating varistor-like behavior.

The number of grain-boundary interfaces between conducting electrodes determines "Breakdown Voltage" of the device. High voltage applications such as AC line protection require many grains between electrodes while low voltage requires few grains to establish the appropriate breakdown voltage. Single layer ceramic disc processing proved to be a viable production method for thick cross section devices with many grains, but attempts to address low voltage suppression needs by processing single layer ceramic disc formulations with huge grain sites has had limited success.

AVX, the world leader in the manufacture of multilayer ceramic capacitors, now offers the low voltage transient protection marketplace a true multilayer, monolithic surface mount varistor. Technology leadership in processing thin dielectric materials and patented processes for precise ceramic grain growth have yielded superior energy dissipation in the smallest size. Now a varistor has voltage characteristics determined by design and not just cell sorting whatever falls out of the process.

Multilayer ceramic varistors are manufactured by mixing ceramic powder in an organic binder (slurry) and casting it into thin layers of precision thickness. Metal electrodes are deposited onto the green ceramic layers which are then stacked to form a laminated structure. The metal electrodes are arranged so that their terminations alternate from one end of the varistor to the other. The device becomes a monolithic block during the sintering (firing) cycle providing uniform energy dissipation in a small volume.

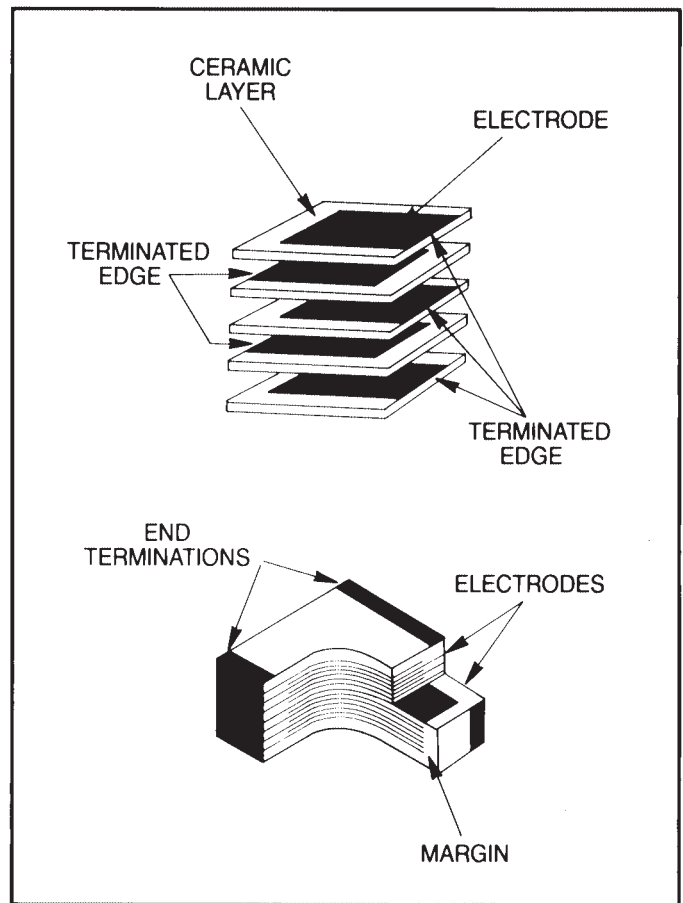
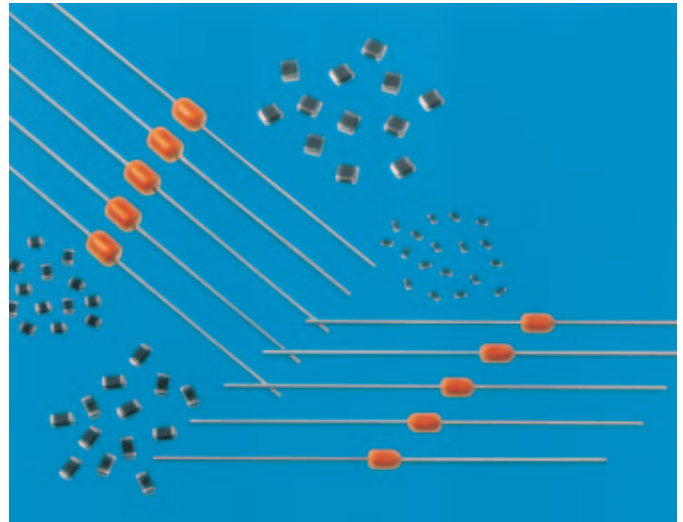

PART NUMBER IDENTIFICATION

Surface Mount Devices

Axial Leaded Devices

Important: For part number identification only, not for construction of part numbers.

The information below only defines the numerical value of part number digits, and cannot be used to construct a desired set of electrical limits. Please refer to the TransGuard® part number data for the correct electrical ratings.

Important: For part number identification only, not for construction of part numbers.

The information below only defines the numerical value of part number digits, and cannot be used to construct a desired set of electrical limits. Please refer to the TransGuard® part number data for the correct electrical ratings.

TERMINATION FINISH:
 P = Ni/Sn Alloy (Plated)
 M = Ni/Sn Pb (Plated)

PACKAGING (Pcs/Reel):

Where: 100 = 12V 500 = 50V
 150 = 18V 560 = 60V
 200 = 22V 580 = 60V
 250 = 27V 620 = 67V
 300 = 32V 650 = 67V
 390 = 42V 101 = 100V
 400 = 42V 121 = 120V

ENERGY:
 Where: A = 0.1J J = 1.5J S = 1.9-2.0J
 B = 0.2J K = 0.6J T = 0.01J
 C = 0.3J L = 0.8J U = 4.0-5.0J
 D = 0.4J M = 1.0J V = 0.02J
 E = 0.5J N = 1.1J W = 6.0J
 F = 0.7J P = 3.0J X = 0.05J
 G = 0.9J Q = 1.3J Y = 12.0J
 H = 1.2J R = 1.7J Z = 25.0J

WORKING VOLTAGE:
 Where: 03 = 3.3 VDC 18 = 18.0 VDC
 05 = 5.6 VDC 26 = 26.0 VDC
 09 = 9.0 VDC 30 = 30.0 VDC
 12 = 12.0 VDC 48 = 48.0 VDC
 14 = 14.0 VDC 60 = 60.0 VDC

CASE SIZE DESIGNATOR:

SIZE	LENGTH	WIDTH
0402	1.00±0.10mm (0.040"±0.004")	0.5±0.10mm (0.020"±0.004")
0603	1.60±0.15mm (0.063"±0.006")	0.8±0.15mm (0.032"±0.006")
0805	2.01±0.2mm (0.079"±0.008")	1.25±0.2mm (0.049"±0.008")
1206	3.20±0.2mm (0.126"±0.008")	1.60±0.2mm (0.063"±0.008")
1210	3.20±0.2mm (0.126"±0.008")	2.49±0.2mm (0.098"±0.008")

CASE STYLE:
 C = Chip

PRODUCT DESIGNATOR:
 V = Varistor

LEAD FINISH:
 Copper clad steel, solder coated

PACKAGING (Pcs/Reel):

STYLE	"D"	"R"	"T"
VA1000	1,000	3,000	7,500
VA2000	1,000	2,500	5,000

CLAMPING VOLTAGE:
 Where: 100 = 12V 580 = 60V
 150 = 18V 650 = 67V
 300 = 32V 101 = 100V
 400 = 42V 121 = 120V

ENERGY:
 Where: A = 0.1J
 D = 0.4J
 K = 2.0J

WORKING VOLTAGE:
 Where: 03 = 3.3 VDC 26 = 26.0 VDC
 05 = 5.6 VDC 30 = 30.0 VDC
 14 = 14.0 VDC 48 = 48.0 VDC
 18 = 18.0 VDC 60 = 60.0 VDC

CASE SIZE DESIGNATOR:

SIZE	LENGTH	DIAMETER
1000	4.32mm (0.170")	2.54mm (0.100")
2000	4.83mm (0.190")	3.56mm (0.140")

CASE STYLE:
 A = Axial

PRODUCT DESIGNATOR:
 V = Varistor

MARKING:
 All axial TransGuards® are marked with vendor identification, product identification, voltage/energy rating code and date code (see example below):

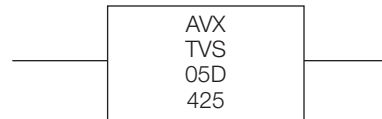

Where: AVX = Always AVX (Vendor Identification)
 TVS = Always TVS (Product Identification - Transient Voltage Suppressor)
 05D = Working VDC and Energy Rating (Joules)
 Where: 05 = 5.6 VDC, D = 0.4J
 425 = Three Digit Date Code
 Where: 4 = Last digit of year (2004)
 25 = Week of year

MARKING:
 All standard surface mount TransGuard® chips will **not** be marked.

AVX Multilayer Ceramic Transient Voltage Suppressors

ELECTRICAL CHARACTERISTICS

AVX Part Number	Working Voltage (DC)	Working Voltage (AC)	Breakdown Voltage	Clamping Voltage	Test Current For V_c	Maximum Leakage Current	Transient Energy Rating	Peak Current Rating	Typical Cap	Frequency	Case Size
VC060303A100 __	3.3	2.3	5.0±20%	12	1	100	0.1	30	1450	K	0603
VC080503A100 __	3.3	2.3	5.0±20%	12	1	100	0.1	40	1400	K	0805
VC080503C100 __	3.3	2.3	5.0±20%	12	1	100	0.3	120	5000	K	0805
VC120603A100 __	3.3	2.3	5.0±20%	12	1	100	0.1	40	1250	K	1206
VC120603D100 __	3.3	2.3	5.0±20%	12	1	100	0.4	150	4700	K	1206
VA100003A100 __	3.3	2.3	5.0±20%	12	1	100	0.1	40	1500	K	1000
VA100003D100 __	3.3	2.3	5.0±20%	12	1	100	0.4	150	4700	K	1000
VC040205X150 __	5.6	4.0	8.5±20%	18	1	35	0.05	20	175	M	0402
VC060305A150 __	5.6	4.0	8.5±20%	18	1	35	0.1	30	750	K	0603
VC080505A150 __	5.6	4.0	8.5±20%	18	1	35	0.1	40	1100	K	0805
VC080505C150 __	5.6	4.0	8.5±20%	18	1	35	0.3	120	3000	K	0805
VC120605A150 __	5.6	4.0	8.5±20%	18	1	35	0.1	40	1200	K	1206
VC120605D150 __	5.6	4.0	8.5±20%	18	1	35	0.4	150	3000	K	1206
VA100005A150 __	5.6	4.0	8.5±20%	18	1	35	0.1	40	1000	K	1000
VA100005D150 __	5.6	4.0	8.5±20%	18	1	35	0.4	150	2800	K	1000
VC040209X200 __	9.0	6.4	12.7±15%	22	1	25	0.05	20	175	M	0402
VC060309A200 __	9.0	6.4	12.7±15%	22	1	25	0.1	30	550	K	0603
VC080509A200 __	9.0	6.4	12.7±15%	22	1	25	0.1	40	750	K	0805
VC080512A250 __	12.0	8.5	16±15%	27	1	25	0.1	40	525	K	0805
VC040214X300 __	14.0	10.0	18.5±12%	32	1	15	0.05	20	100	M	0402
VC060314A300 __	14.0	10.0	18.5±12%	32	1	15	0.1	30	350	K	0603
VC080514A300 __	14.0	10.0	18.5±12%	32	1	15	0.1	40	325	K	0805
VC080514C300 __	14.0	10.0	18.5±12%	32	1	15	0.3	120	900	K	0805
VC120614A300 __	14.0	10.0	18.5±12%	32	1	15	0.1	40	600	K	1206
VC120614D300 __	14.0	10.0	18.5±12%	32	1	15	0.4	150	1050	K	1206
VA100014A300 __	14.0	10.0	18.5±12%	32	1	15	0.1	40	325	K	1000
VA100014D300 __	14.0	10.0	18.5±12%	32	1	15	0.4	150	1100	K	1000
VC13MA0160KBA	16.0	14.0	24.5±10%	40	2.5	25	1.6	400	1800	K	1210
VC040218X400 __	18.0	13.0	25.5±10%	42	1	10	0.05	20	65	M	0402
VC060318A400 __	18.0	13.0	25.5±10%	42	1	10	0.1	30	150	K	0603
VC080518A400 __	18.0	13.0	25.5±10%	42	1	10	0.1	30	225	K	0805
VC080518C400 __	18.0	13.0	25.5±10%	42	1	10	0.3	100	550	K	0805
VC120618A400 __	18.0	13.0	25.5±10%	42	1	10	0.1	30	350	K	1206
VC120618D400 __	18.0	13.0	25.5±10%	42	1	10	0.4	150	900	K	1206
VC120618E380 __	18.0	13.0	22.0±10%	38	1	15	0.5	200	800	K	1206
VC121018J390 __	18.0	13.0	25.5±10%	42	5	10	1.5	500	3100	K	1210
VJ13MC0180KBA	18.0	13.0	24.0±10%	45	10	25	1.5	500	3000	K	1210
VA100018A400 __	18.0	13.0	25.5±10%	42	1	10	0.1	40	350	K	1000

└ Termination/Lead Finish Code
└ Packaging Code

ELECTRICAL CHARACTERISTICS

AVX Part Number	Working Voltage (DC)	Working Voltage (AC)	Breakdown Voltage	Clamping Voltage	Test Current For V _c	Maximum Leakage Current	Transient Energy Rating	Peak Current Rating	Typical Cap	Frequency	Case Size
VA100018D400 __	18.0	13.0	25.5±10%	42	1	10	0.4	150	900	K	1000
VC060326A580 __	26.0	18.0	34.5±10%	60	1	10	0.1	30	155	K	0603
VC080526A580 __	26.0	18.0	34.5±10%	60	1	10	0.1	30	120	K	0805
VC080526C580 __	26.0	18.0	34.5±10%	60	1	10	0.3	100	250	K	0805
VC120626D580 __	26.0	18.0	34.5±10%	60	1	10	0.4	120	500	K	1206
VC120626F540 __	26.0	20.0	33.0±10%	54	1	15	0.7	200	600	K	1206
VC121026H560 __	26.0	18.0	34.5±10%	60	5	10	1.2	300	2150	K	1210
VJ13MC0260KBA	26.0	18.0	33.0±10%	62	10	25	1.2	300	1120	K	1210
VC181226P540 __	26.0	20.0	33.0±10%	54	5	15	3.0	800	3000	K	1812
VA100026D580 __	26.0	18.0	34.5±10%	60	1	10	0.4	120	650	K	1000
VC060330A650 __	30.0	21.0	41.0±10%	67	1	10	0.1	30	125	K	0603
VC080530A650 __	30.0	21.0	41.0±10%	67	1	10	0.1	30	90	M	0805
VC120630D650 __	30.0	21.0	41.0±10%	67	1	10	0.4	120	400	K	1206
VC121030G620 __	30.0	21.0	41.0±10%	67	5	10	0.9	220	1750	K	1210
VC121030H620 __	30.0	21.0	41.0±10%	67	5	10	1.2	280	1850	K	1210
VJ13MC0300KBA	30.0	21.0	39.0±10%	73	10	25	0.9	220	1020	K	1210
VJ13PC0300KBA	30.0	21.0	39.0±10%	73	10	25	1.2	280	1150	K	1210
VA100030D650 __	30.0	21.0	41.0±10%	67	1	10	0.4	120	550	K	1000
VC120631M650 __	31.0	25.0	39.0±10%	65	1	15	1.0	200	500	K	1206
VC120638N770 __	38.0	30.0	47.0±10%	77	1	15	1.1	200	350	K	1206
VC121038S770 __	38.0	30.0	47.0±10%	77	2.5	15	2.0	300	750	K	1210
VC181238U770 __	38.0	30.0	47.0±10%	77	5	15	4.2	800	1700	K	1812
VC120645K900 __	45.0	35.0	56.0±10%	90	1	15	0.6	200	260	K	1206
VC181245U900 __	45.0	35.0	56.0±10%	90	5	15	4.0	500	1200	K	1812
VC120648D101 __	48.0	34.0	62.0±10%	100	1	10	0.4	100	225	K	1206
VC121048G101 __	48.0	34.0	62.0±10%	100	5	10	0.9	220	450	K	1210
VC121048H101 __	48.0	34.0	62.0±10%	100	5	10	1.2	250	500	K	1210
VJ13MC0480KBA	48.0	34.0	60.5±10%	110	10	25	0.9	220	800	K	1210
VJ13PC0480KBA	48.0	34.0	60.5±10%	110	10	25	1.2	250	840	K	1210
VA100048D101 __	48.0	34.0	62.0±10%	100	1	10	0.4	100	200	K	1000
VC120656F111 __	56.0	40.0	68.0±10%	110	1	15	0.7	100	180	K	1206
VC181256U111 __	56.0	40.0	68.0±10%	110	5	15	4.8	500	800	K	1812
VC121060J121 __	60.0	42.0	76.0±10%	120	5	10	1.5	250	400	K	1210
VJ13MC0600KBA	60.0	42.0	75.0±10%	126	10	25	1.5	250	600	K	1210
VA200060K121 __	60.0	42.0	76.0±10%	120	1	10	2.0	300	400	K	2000
VC120665L131 __	65.0	50.0	82.0±10%	135	1	15	0.8	100	120	K	1206

Termination/Lead Finish Code
 Packaging Code

V_w(DC) DC Working Voltage (V)
 V_w(AC) AC Working Voltage (V)
 V_b Typical Breakdown Voltage (V @ 1mA_{DC})
 V_b Tol V_b Tolerance is ± from Typical Value
 V_c Clamping Voltage (V @ I_c)

I_c Test Current for V_c (A, 8x20µS)
 I_l Maximum Leakage Current at the Working Voltage (µA)
 E_T Transient Energy Rating (J, 10x1000µS)
 I_p Peak Current Rating (A, 8x20µS)
 Cap Typical Capacitance (pF) @ frequency specified and 0.5 V_{RMS}
 Freq Frequency at which capacitance is measured (K = 1kHz, M = 1MHz)

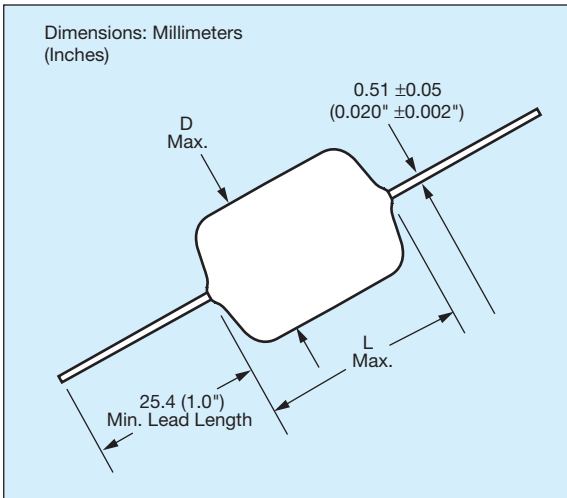

DIMENSIONS: mm (inches)

AVX Style		VA1000	VA2000
(L) Max Length	mm (in.)	4.32 (0.170)	4.83 (0.190)
(D) Max Diameter	mm (in.)	2.54 (0.100)	3.56 (0.140)

Lead Finish: Copper Clad Steel, Solder Coated

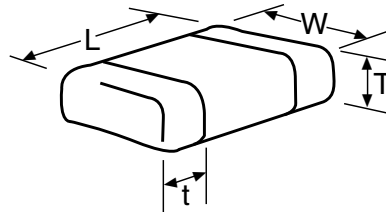

DIMENSIONS: mm (inches)

AVX Style		0402	0603	0805	1206	1210	1812	2220
(L) Length	mm (in.)	1.00±0.10 (0.040±0.004)	1.60±0.15 (0.063±0.006)	2.01±0.20 (0.079±0.008)	3.20±0.20 (0.126±0.008)	3.20±0.20 (0.126±0.008)	4.50±0.20 (0.177±0.008)	5.70±0.20 (0.224±0.008)
(W) Width	mm (in.)	0.50±0.10 (0.020±0.004)	0.80±0.15 (0.031±0.006)	1.25±0.20 (0.049±0.008)	1.60±0.20 (0.063±0.008)	2.49±0.20 (0.098±0.008)	3.20±0.20 (0.126±0.008)	5.00±0.20 (0.197±0.008)
(T) Max Thickness	mm (in.)	0.6 (0.024)	0.9 (0.035)	1.02 (0.040)	1.02 (0.040)	1.70 (0.067)	1.70 (0.067)	1.70 (0.067)
(t) Land Length	mm (in.)	0.25±0.15 (0.010±0.006)	0.35±0.15 (0.014±0.006)	0.71 max. (0.028 max.)	0.71 max. (0.028 max.)	0.71 max. (0.028 max.)	0.50±0.25 (0.020±0.010)	0.50±0.25 (0.020±0.010)

AVX Multilayer Ceramic Transient Voltage Suppressors

TYPICAL PERFORMANCE CURVES (0402 CHIP SIZE)

VOLTAGE/CURRENT CHARACTERISTICS

Multilayer construction and improved grain structure result in excellent transient clamping characteristics up to 20 amps peak current, while maintaining very low leakage currents under DC operating conditions. The VI curves below show the voltage/current characteristics for the 5.6V, 9V, 14V, 18V and low capacitance StaticGuard parts with currents ranging from parts of a micro amp to tens of amps.

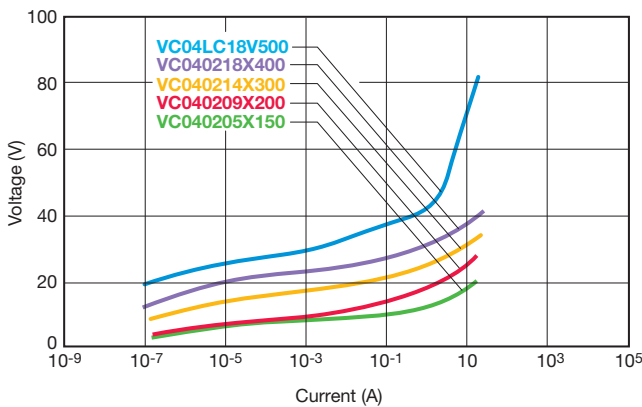

PULSE DEGRADATION

Traditionally varistors have suffered degradation of electrical performance with repeated high current pulses resulting in decreased breakdown voltage and increased leakage current. It has been suggested that irregular intergranular boundaries and bulk material result in restricted current paths and other non-Schottky barrier paralleled conduction paths in the ceramic. Repeated pulsing of TransGuard transient voltage suppressors with 150Amp peak 8 x 20µS waveforms shows negligible degradation in breakdown voltage and minimal increases in leakage current. This does not mean that TransGuard suppressors do not suffer degradation, but it occurs at much higher current.

ESD TEST OF 0402 PARTS

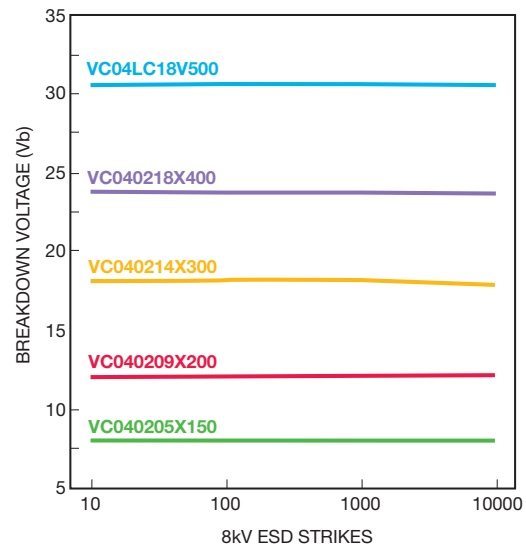

PEAK POWER VS PULSE DURATION

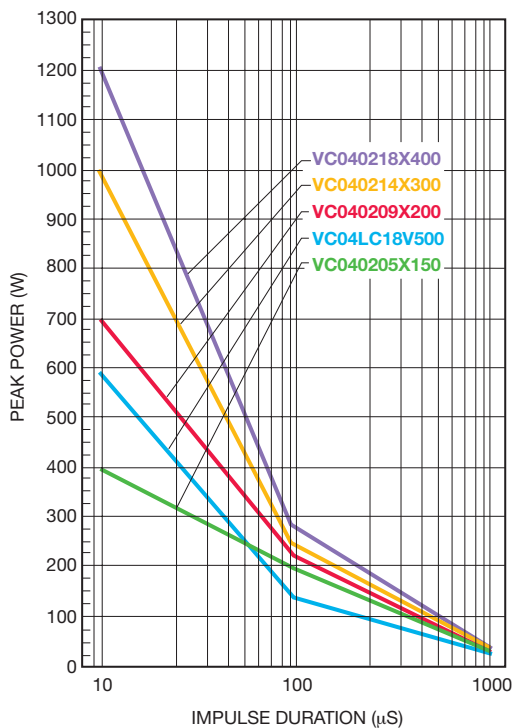

INSERTION LOSS CHARACTERISTICS

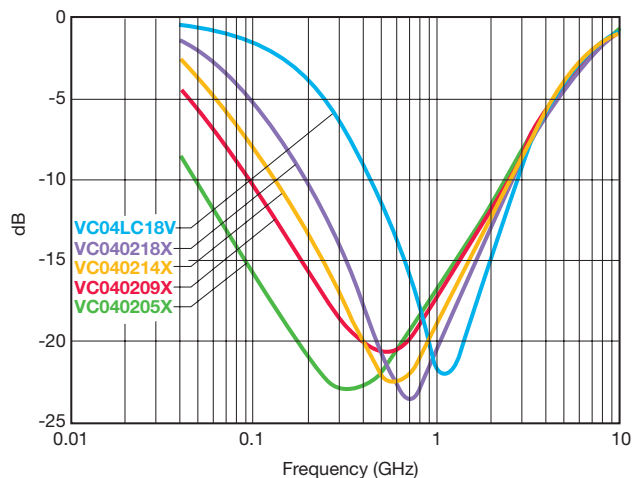

TYPICAL PERFORMANCE CURVES (0603, 0805, 1206 & 1210 CHIP SIZES)

VOLTAGE/CURRENT CHARACTERISTICS

Multilayer construction and improved grain structure result in excellent transient clamping characteristics up to 500 amps peak current, depending on case size and energy rating, while maintaining very low leakage currents under DC operating conditions. The VI curve below shows the voltage/current characteristics for the 3.3V, 5.6V, 12V, 14V, 18V, 26V, 30V, 48V and 60VDC parts with currents ranging from parts of a micro amp to tens of amps.

VI Curves - 3.3V and 5.6V Products

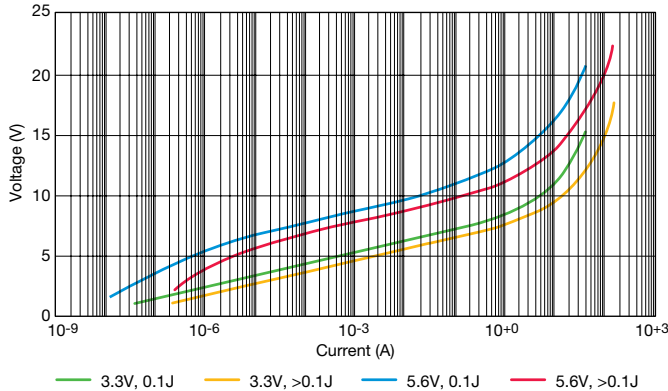

VI Curves - 9V, 12V, and 14V Products

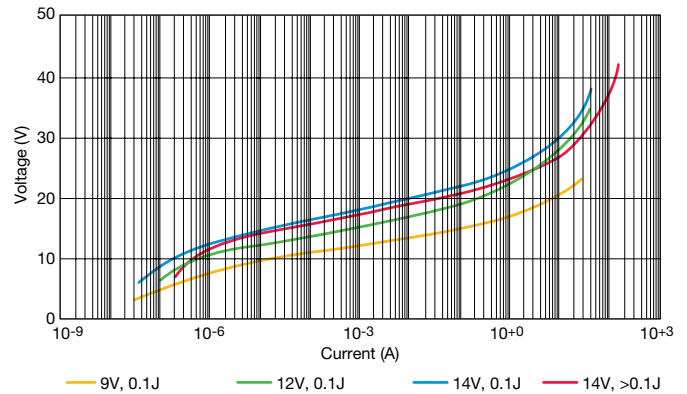

VI Curves - 18V and 26V Products

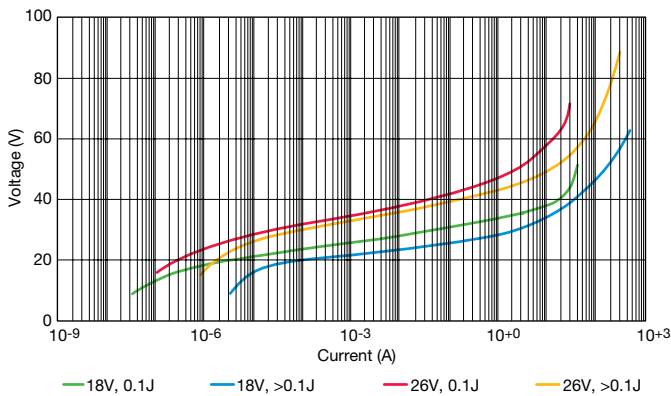

VI Curves - 30V, 48V, and 60V Products

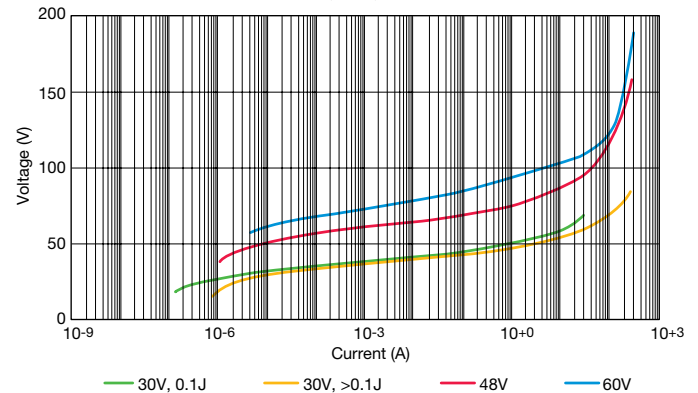

AVX Multilayer Ceramic Transient Voltage Suppressors

TYPICAL PERFORMANCE CURVES (0603, 0805, 1206 & 1210 CHIP SIZES)

TYPICAL PULSE RATING CURVE
3.3V MULTILAYER TRANSGUARD®

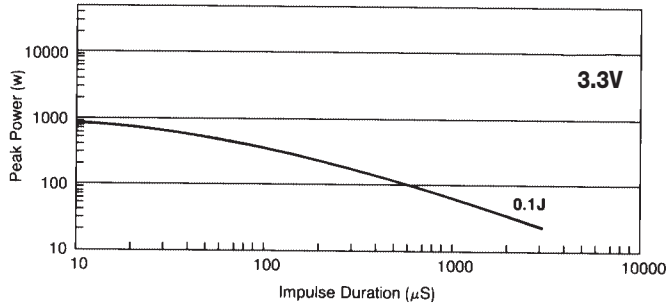

TYPICAL PULSE RATING CURVE
26V MULTILAYER TRANSGUARD®

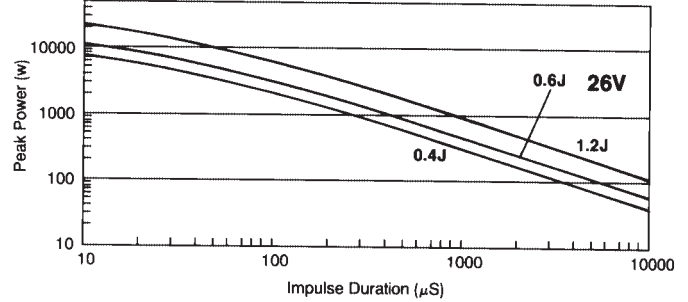

TYPICAL PULSE RATING CURVE
5.6V MULTILAYER TRANSGUARD®

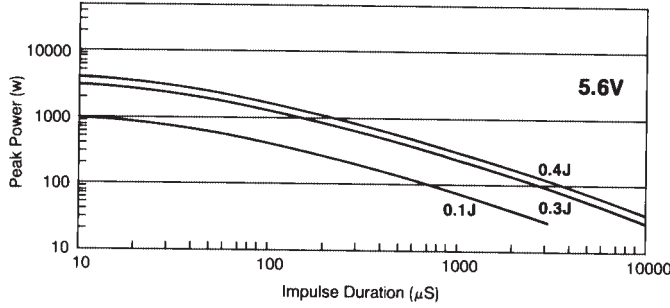

TYPICAL PULSE RATING CURVE
30V MULTILAYER TRANSGUARD®

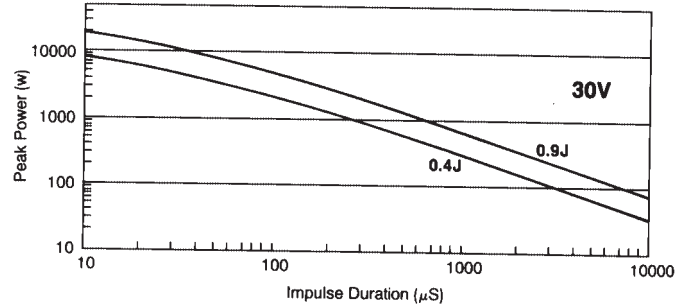

TYPICAL PULSE RATING CURVE
14V MULTILAYER TRANSGUARD®

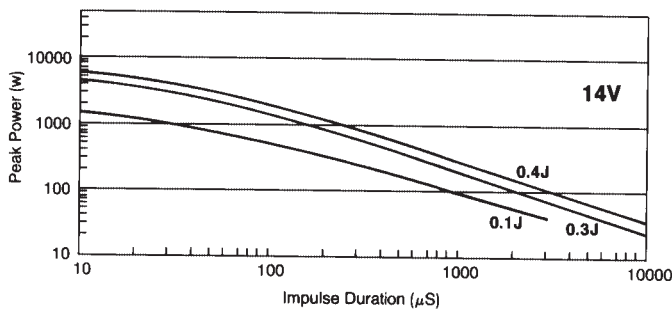

TYPICAL PULSE RATING CURVE
48V MULTILAYER TRANSGUARD®

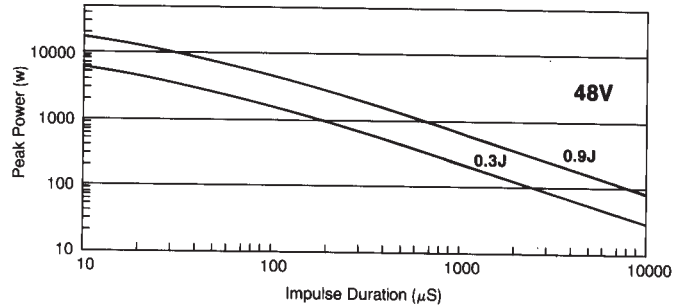

TYPICAL PULSE RATING CURVE
18V MULTILAYER TRANSGUARD®

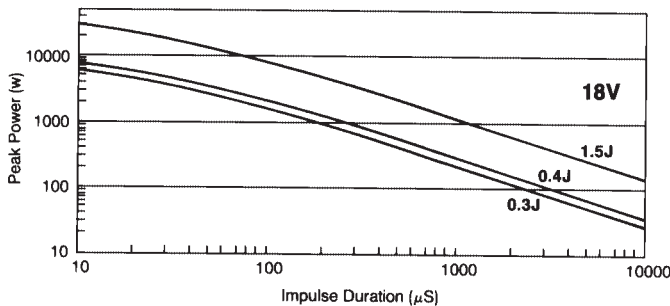

TYPICAL PULSE RATING CURVE
60V MULTILAYER TRANSGUARD®

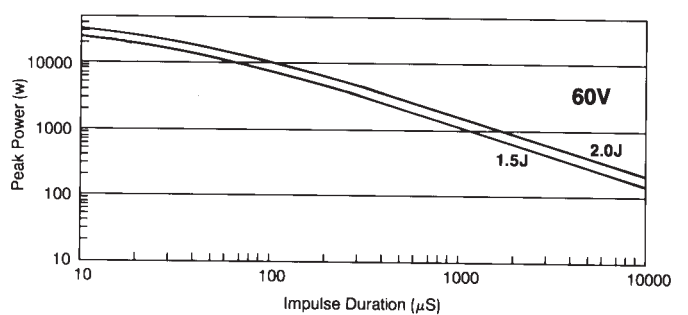

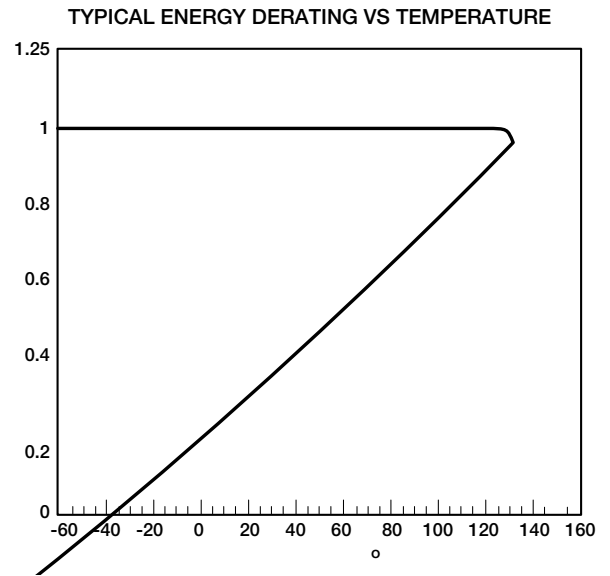
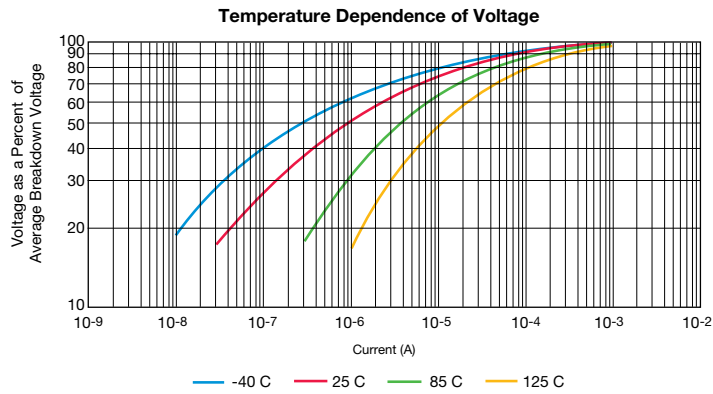

TYPICAL PERFORMANCE CURVES (0603, 0805, 1206 & 1210 CHIP SIZES)

PULSE DEGRADATION

Traditionally varistors have suffered degradation of electrical performance with repeated high current pulses resulting in decreased breakdown voltage and increased leakage current. It has been suggested that irregular intergranular boundaries and bulk material result in restricted current paths and other non-Schottky barrier paralleled conduction paths in the ceramic. Repeated pulsing of both 5.6 and 14V TransGuard transient voltage suppressors with

150 Amp peak $8 \times 20\mu\text{s}$ waveforms shows negligible degradation in breakdown voltage and minimal increases in leakage current. This does not mean that TransGuard suppressors do not suffer degradation, but it occurs at much higher current. The plots of typical breakdown voltage vs number of 150A pulses are shown below.

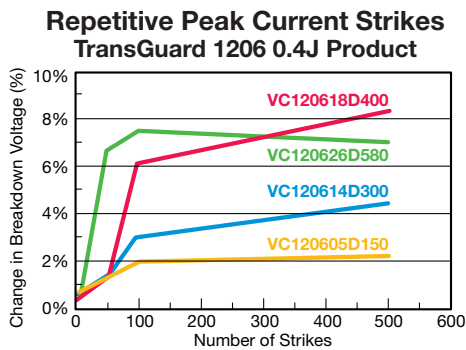

Figure 1

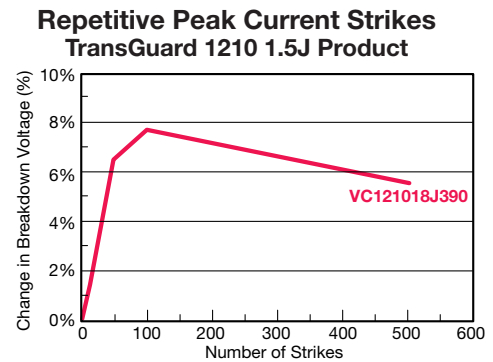

Figure 3

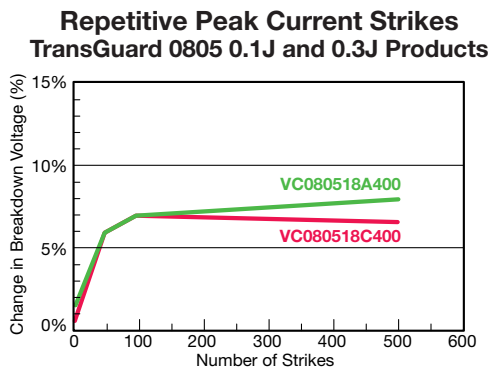

Figure 2

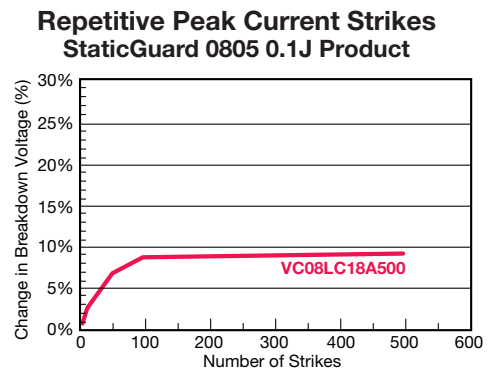
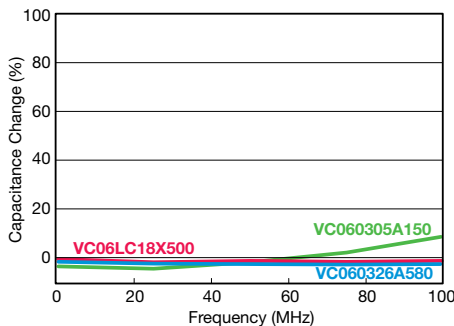

Figure 4

CAPACITANCE/FREQUENCY CHARACTERISTICS

TransGuard Capacitance vs Frequency 0603



TransGuard Capacitance vs Frequency 0805

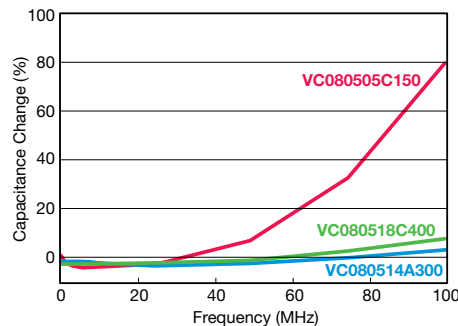

TransGuard Capacitance vs Frequency 1206

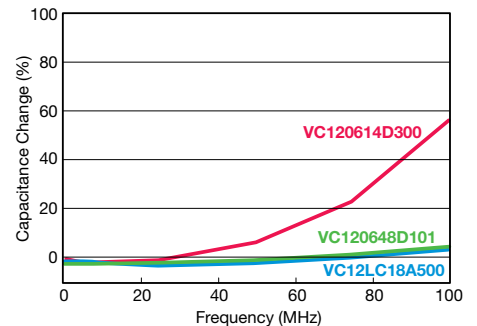

Medium Power MLV (VC13, 14, 15, 20)



Medium Power Multilayer Chip Varistor

Transient Voltage Suppression, ESD Protection Devices & EMI Devices

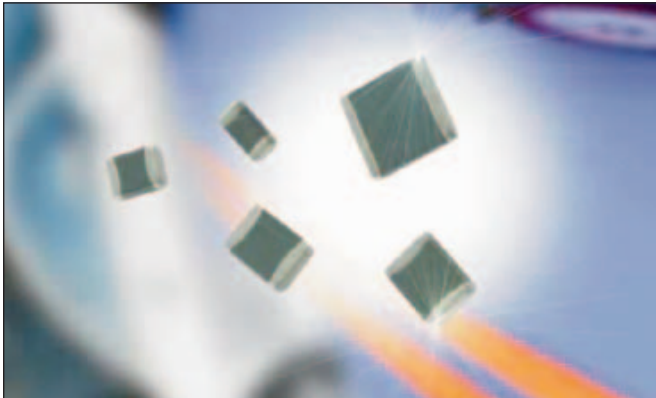

GENERAL DESCRIPTION

AVX's Transient Voltage Suppression (TVS) devices address six trends in today's electronic circuits: (1) mandatory ESD protection, (2) mandatory EMI control, (3) signal integrity improvement, (4) PCB downsizing, (5) reduced component placement costs, and (6) protection from induced slow speed transient voltages and currents.

AVX's Medium Power Multilayer Varistors include 3 series of products as listed below:

- Standard 1210 Series (VJ13)
- Telecom Series (VC14)
- Automotive Range (VC13, 14, 15, 20)

TYPICAL APPLICATIONS

Mainly used to reduce transient over-voltages in a very wide range of electronic products. Some example applications are 1) Telecom, 2) Automotive, 3) Consumer Electronics, and 4) Industrial Applications.

PHYSICAL DIMENSIONS: mm (inches)

	Type	IEC Size	L	I	bm	t max
	VC20	1206	3.20±0.20 (0.126±0.008)	1.60±0.20 (0.063±0.008)	0.50±0.25 (0.020±0.010)	1.70 (0.067)
VC13	1210	3.20±0.20 (0.126±0.008)	2.50±0.20 (0.098±0.008)	0.50±0.25 (0.020±0.010)	1.70 (0.067)	
VC14	1812	4.50±0.20 (0.177±0.008)	3.20±0.20 (0.126±0.008)	0.50±0.25 (0.020±0.010)	1.70 (0.067)	
VC15	2220	5.70±0.20 (0.224±0.008)	5.00±0.20 (0.197±0.008)	0.50±0.25 (0.020±0.010)	1.70 (0.067)	

PART NUMBERING

VC	14	M	T	0950	K	BA
Varistor Series VC = Unplated VJ = Plated	Chip Size 20 = 1206 13 = 1210 14 = 1812 15 = 2220	Code M = Standard P = Pro Grade	Series Code A = Automotive T = Telecom C = Standard	AC Operating Voltage	1mA Voltage Tolerance K = ±10%	Packaging BA = Tape & Reel VC20: 4000 pcs/reel VC13: 2000 pcs/reel VC14: 1500 pcs/reel VC15: 1250 pcs/reel

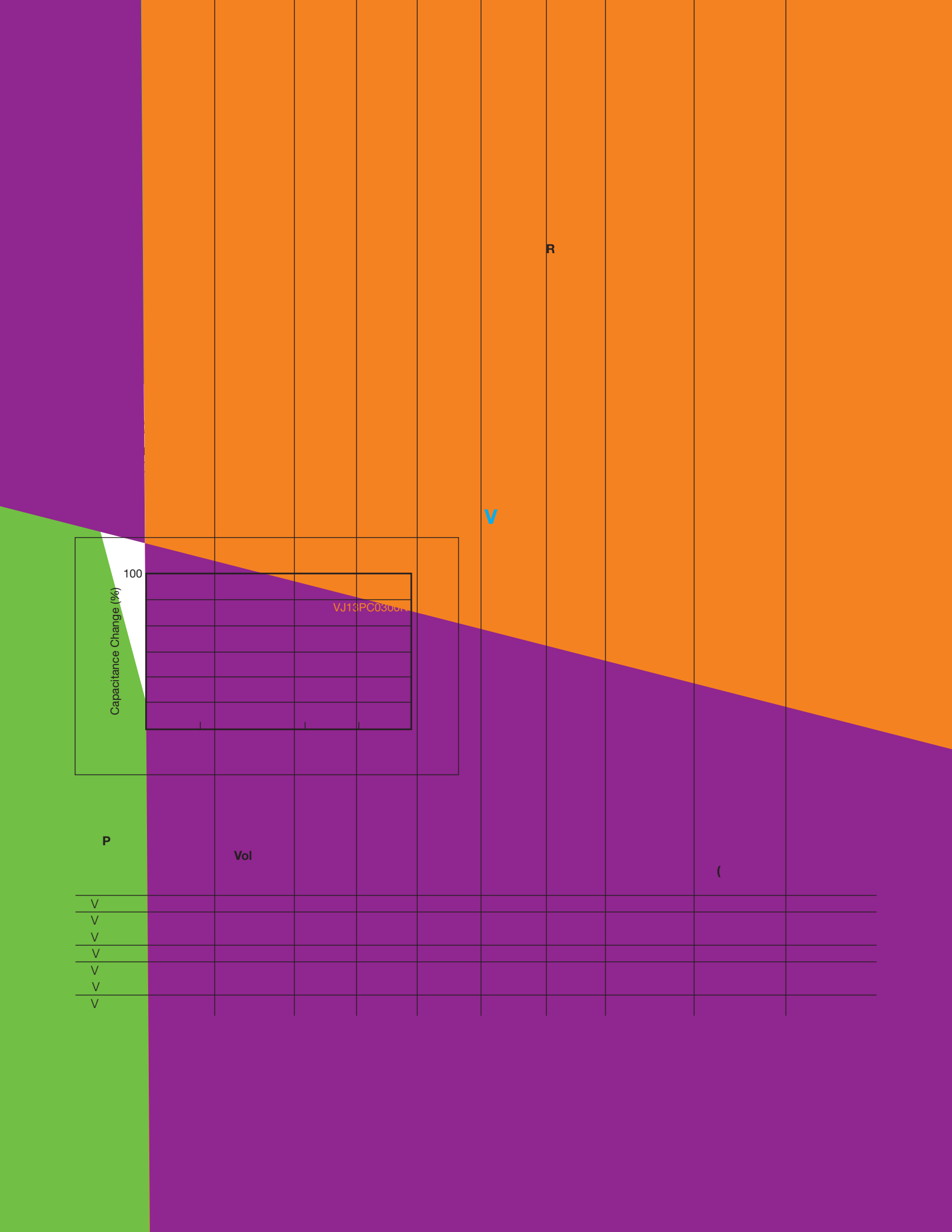

R

V

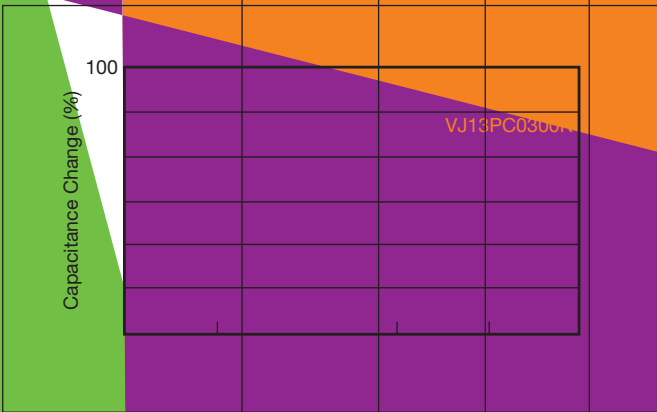

P

Vol

(

- V
- V
- V
- V
- V
- V
- V

STANDARD SERIES - VJ13 (1210)

TEMPERATURE DEPENDENCE OF V/I CHARACTERISTIC

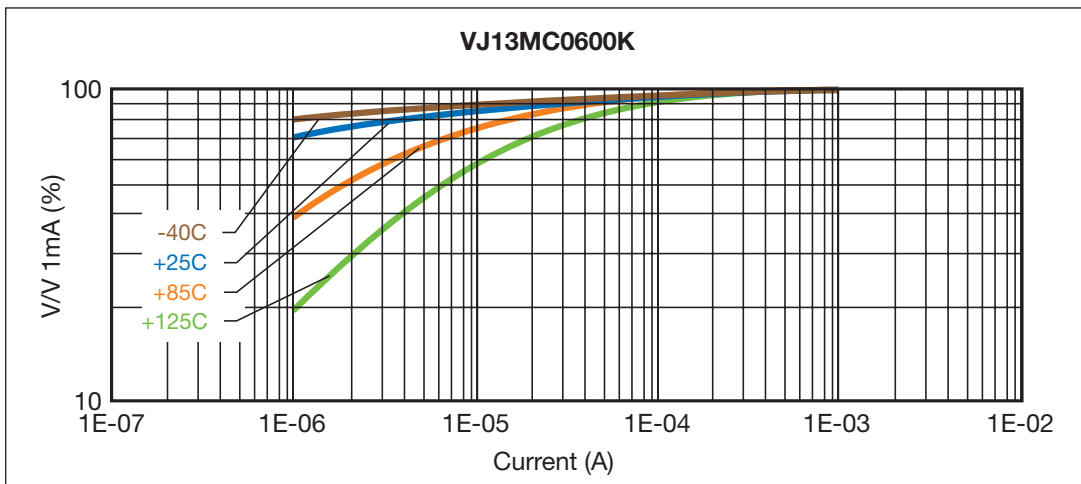
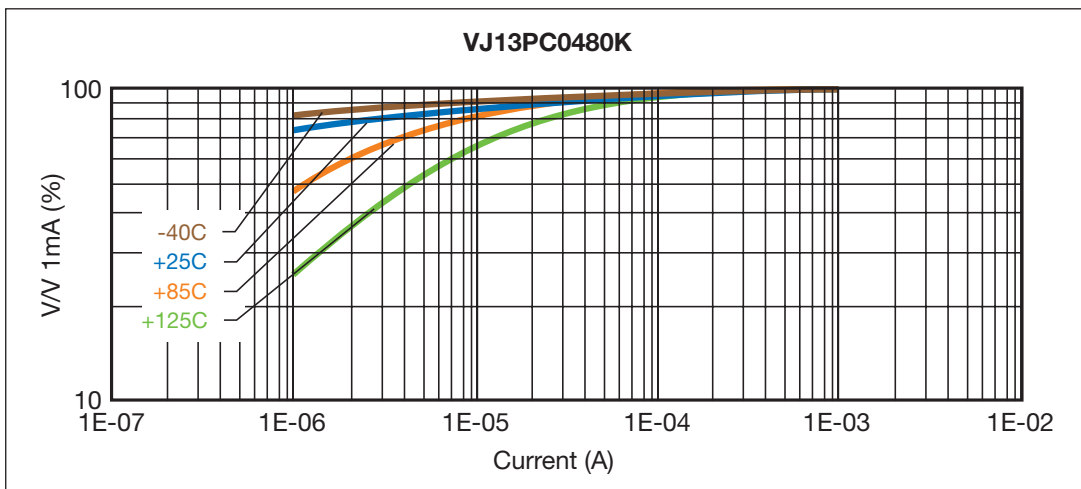
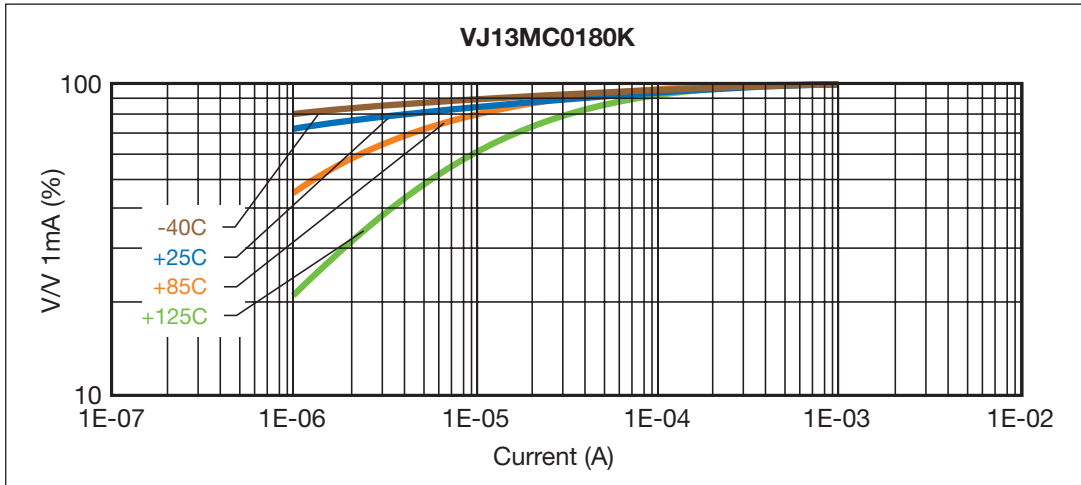

Medium Power MLV (VC13, 14, 15, 20)



Medium Power Multilayer Chip Varistor

Transient Voltage Suppression, ESD Protection Devices & EMI Devices

TELECOM SERIES - VC14 (1812)

FEATURES

- Pd/Ag Terminations
- High Energy Ratings (up to 6 Joules with 1812 case)
- Multiple Strike Capability
- Provides EMC Capacitance
- Effective Alternative to Leaded MOVs between 60-90Vrms
- Specified in accordance to CCITT 10/700ms Pulse test

TARGET APPLICATIONS

- Phone Lines, ADSL Lines, and other Telecom Circuits
- Consumer Products

GENERAL CHARACTERISTICS

Storage Temperature: -55°C to +125°C
 Operating Temperature: -55°C to +125°C

CCITT 10x700µs TEST

A test pulse of 10x700µs duration as specified by CCITT or IEC 61000-4-5 is often used to check the interference immunity of telecom equipment.

The curves show that the 60Vrms varistor can reduce the interference voltage at the equipment connected from 2kV to less than 200V.

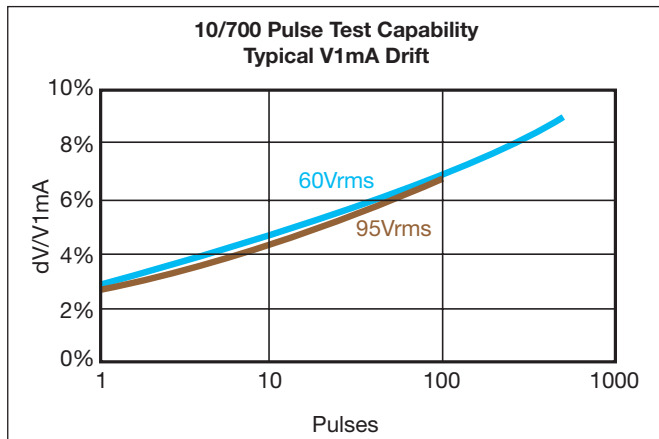
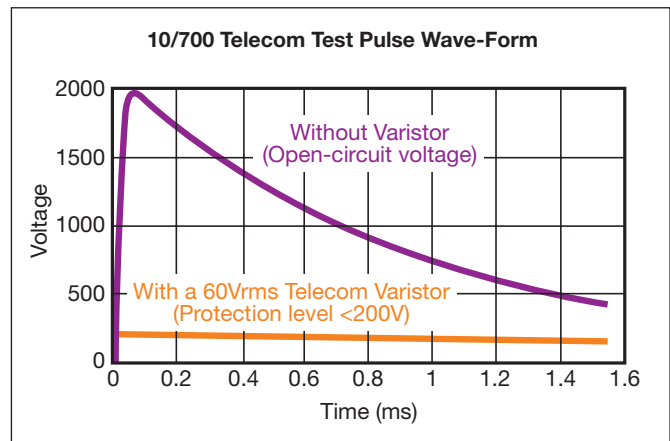

Ten pulses with a duration of 10x700µs applied at one minute intervals are specified for telecom equipment.

The curves show the V1mA drift when more than 10 pulses are applied.

PART NUMBERS

Part Number	Operating Voltage		Vclamp (8x20µs)		Energy (10x1000µs) J	Max Ipeak (8x20µs) 1 Surge Ip (A)	Mean Power Dissipation W	CCITT 10Pulse (10x700µs) V	Typical Cap pF
	Vrms	Vdc	Vp	Ip					
VC14MT0600KBA	60	85	200	45	6	400	0.015	2000	400
VC14MT0950KBA	95	125	270	45	5	250	0.015	2000	250

Medium Power MLV (VC13, 14, 15, 20)



Medium Power Multilayer Chip Varistor

Transient Voltage Suppression, ESD Protection Devices & EMI Devices

AUTOMOTIVE SERIES – VC13, 14, 15, 20

FEATURES

- Pd/Ag Terminations
- High Energy Ratings (up to 25 Joules with 2220 case size)
- Multiple Strike Capability
- Provides EMC Capacitance
- Well suited to protect against automotive related transients
- Specified with “Load Dump” and “Jump Start” Test Requirements

GENERAL CHARACTERISTICS

Storage Temperature: -55°C to +125°C
 Operating Temperature: -55°C to +125°C

TARGET APPLICATIONS

Automotive and other Consumer Products

TEMPERATURE CHARACTERISTICS

For Current, Energy and Power

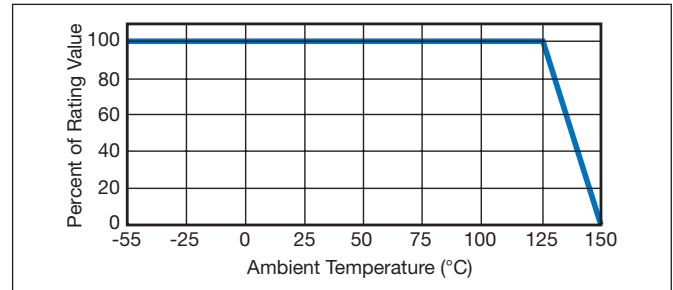

IMPEDANCE CHARACTERISTICS

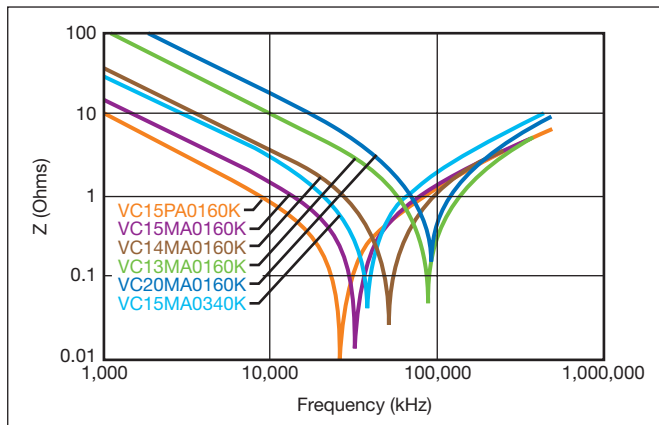

V/I CHARACTERISTICS

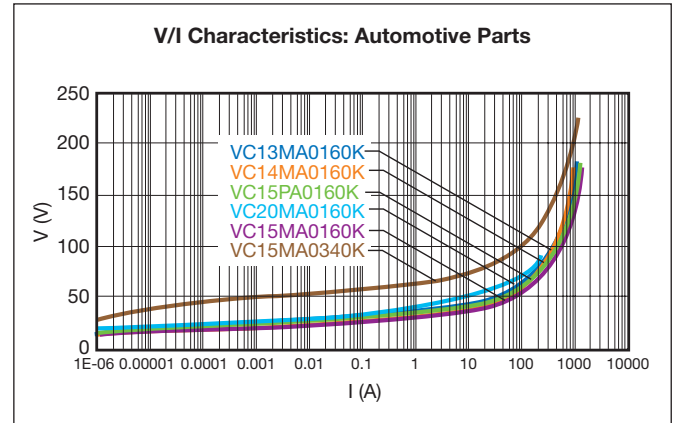

PART NUMBERS

Part Number	Case Size	Operating Voltage		Vnominal At 1mA DC			Vclamp (8x20µs)		Leakage At Vdc µA	Energy (10x1000µs) J	Load Dump (10x) J	Jump Start 5min Max V	Max.Peak Current (8x20µs) Ip (A)	Mean Power Dissipation W	CAP (1kHz/.5Vrms) pF
		Vrms	Vdc	min	Nom	max	Vp	Ip(A)							
VC20MA0160KBA	1206	14	16	22	24.5	27	40	1	50	0.6	1.5	24.5	200	0.008	900
VC13MA0160KBA	1210	14	16	22	24.5	27	40	2.5	25	1.6	3	24.5	400	0.010	1800
VC14MA0160KBA	1812	14	16	22	24.5	27	40	5	100	2.4	6	24.5	800	0.015	5000
VC15MA0160KBA	2220	14	16	22	24.5	27	40	10	100	5.8	12	24.5	1200	0.030	11000
VC15PA0160KBA	2220	14	16	22	24.5	27	40	10	100	5.8	25	24.5	1200	0.030	16000
VC15MA0340KBA	2220	30	34	42.3	47	51.7	77	10	100	12	12	50	1200	0.030	4000



Medium Power MLV (VC13, 14, 15, 20)



Medium Power Multilayer Chip Varistor

Transient Voltage Suppression, ESD Protection Devices & EMI Devices

AUTOMOTIVE SERIES – VC13, 14, 15, 20

AUTOMOTIVE LOAD DUMP TEST

(According to ISO DP7637/2 Pulse 5)

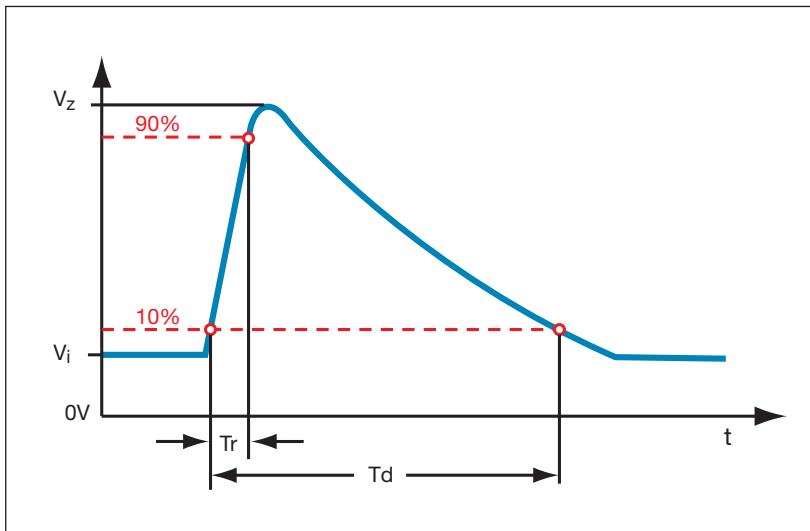

When using the test method indicated below, the amount of Energy dissipated by the varistor must not exceed the Load Dump Energy value specified in the product table.

Voltage Pulse applied to the varistor:

12V Network

$V_i = 13.5V$

$T_d = 100$ to $350ms$

$R_i = 2$ Ohms (Internal Resistance)

$V_z = 70$ to $200V$

Number of Pulses = 10 Pulses

Other Load Dump Simulations can be achieved

24V Network

$V_i = 27V$

$T_d = 100$ to $350ms$

$R_i = 2$ Ohms (Internal Resistance)

$V_z = 70$ to $200V$

Number of Pulses = 10 Pulses

PULSE DEGRADATION

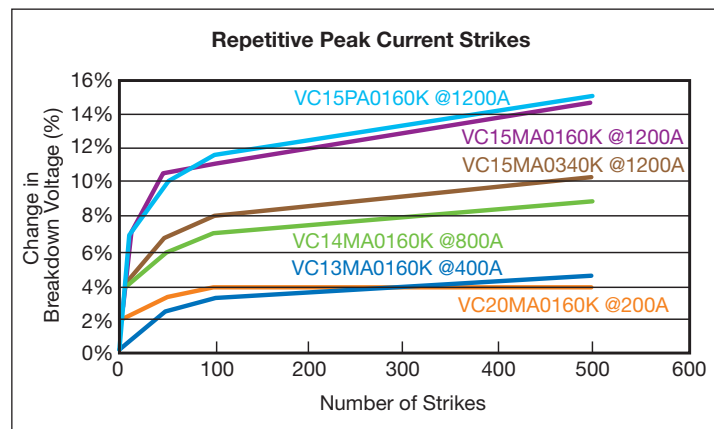

AUTOMOTIVE SERIES – VC13, 14, 15, 20

TEMPERATURE DEPENDENCE OF V/I CHARACTERISTIC

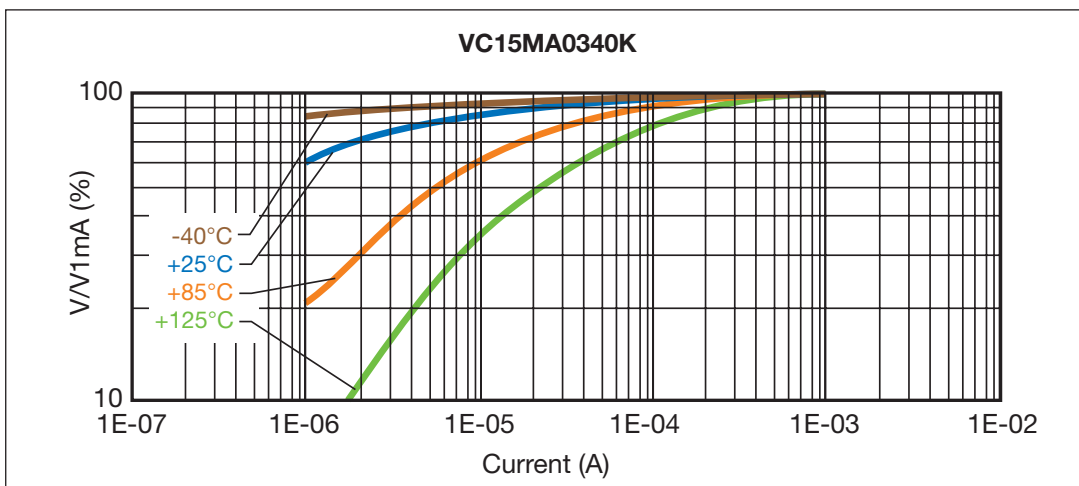
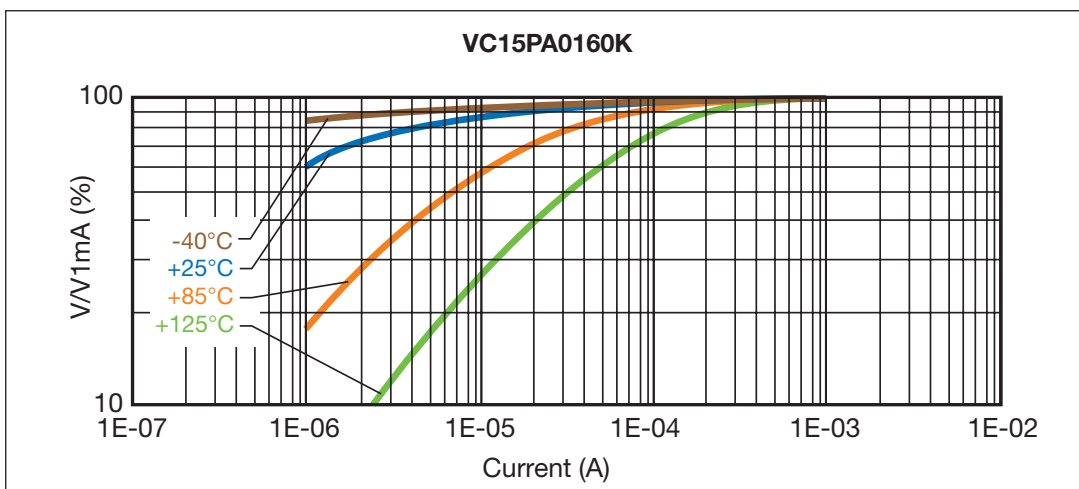
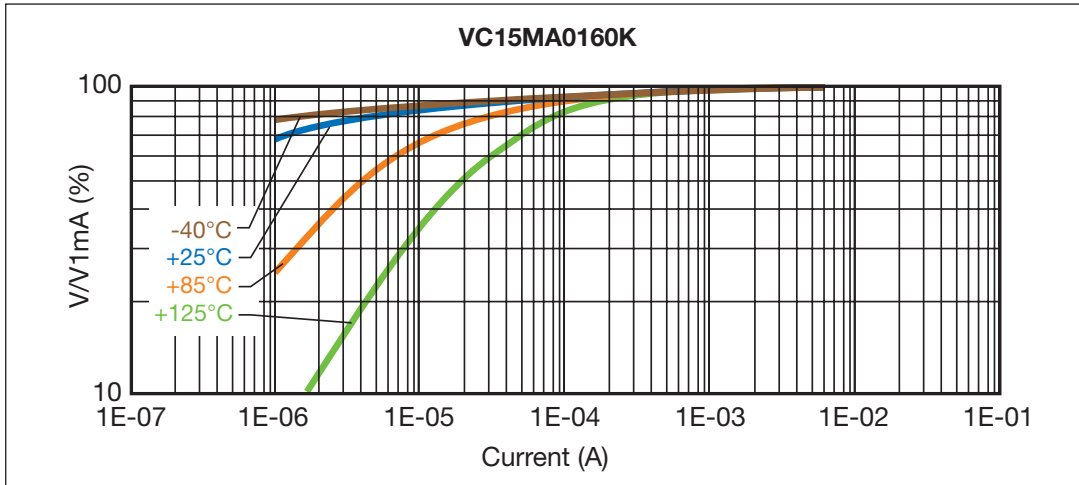

StaticGuard



AVX Multilayer Ceramic Transient Voltage Suppressors ESD Protection for CMOS, Bi Polar and SiGe Based Systems

GENERAL INFORMATION

- Typical ESD failure voltage for CMOS and/or Bi Polar is $\geq 200V$.
- 15kV ESD pulse (air discharge) per IEC 1000-4-2, Level 4, generates < 20 millijoules of energy.
- Low capacitance (<200pF) is required for high-speed data transmission.
- Low leakage current (I_L) is necessary for battery operated equipment.

StaticGuard

AVX Part Number	Working Voltage (DC)	Working Voltage (AC)	Clamping Voltage	Test Current For V_c	Maximum Leakage Current	Transient Energy Rating	Peak Current Rating	Typical Cap	Case Size	Elements
VC04LC18V500_ _	≤ 18.0	≤ 14.0	50	1	10	0.02	15	40	0402	1
VC06LC18X500_ _	≤ 18.0	≤ 14.0	50	1	10	0.05	30	50	0603	1
VC08LC18A500_ _	≤ 18.0	≤ 14.0	50	1	10	0.10	30	80	0805	1
VC12LC18A500_ _	≤ 18.0	≤ 14.0	50	1	10	0.10	30	200	1206	1
VA10LC18A500_ _	≤ 18.0	≤ 14.0	50	1	10	0.10	30	200	Axial	1

Termination/Lead Finish Code
Packaging Code

- V_w (DC) DC Working Voltage (V)
 V_w (AC) AC Working Voltage (V)
 V_c Clamping Voltage (V @ I_{vc})
 I_{vc} Test Current for V_c (A, $8 \times 20\mu S$)
 I_L Maximum Leakage Current at the Working Voltage (μA)
 E_T Transient Energy Rating (J, $10 \times 1000\mu S$)
 I_p Peak Current Rating (A, $8 \times 20\mu S$)
 Cap Typical Capacitance (pF) @ frequency specified and 0.5 V

PART NUMBER IDENTIFICATION

Chips

VC08LC18A500RP

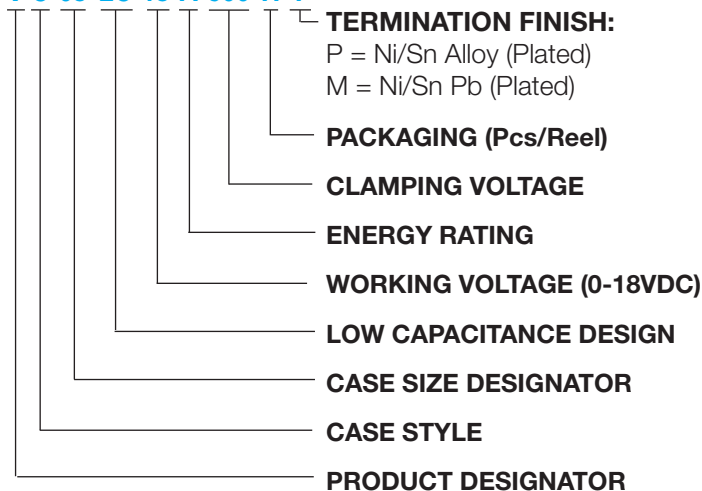

Axials

VA10LC18A500RL

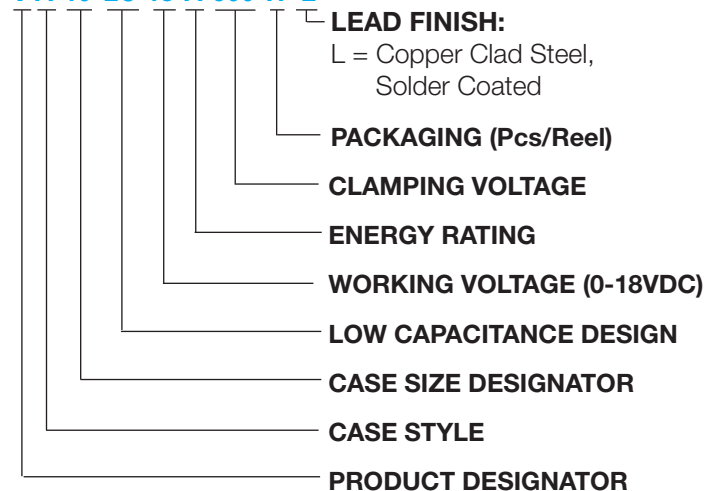

TYPICAL PERFORMANCE DATA

VC06LC18X500 Capacitance Histogram

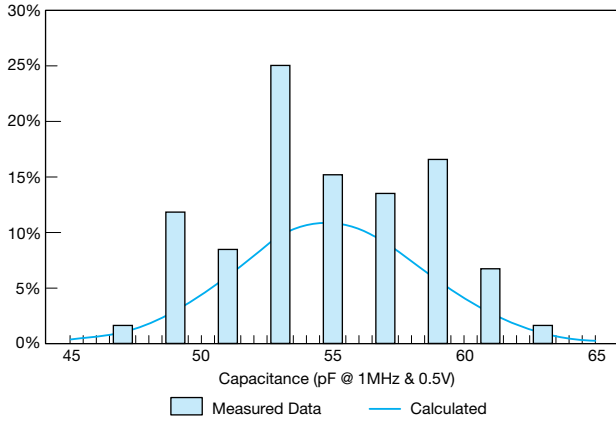

StaticGuard ESD RESPONSE
IEC 1000-4-2 (8 Kv Contact Discharge)

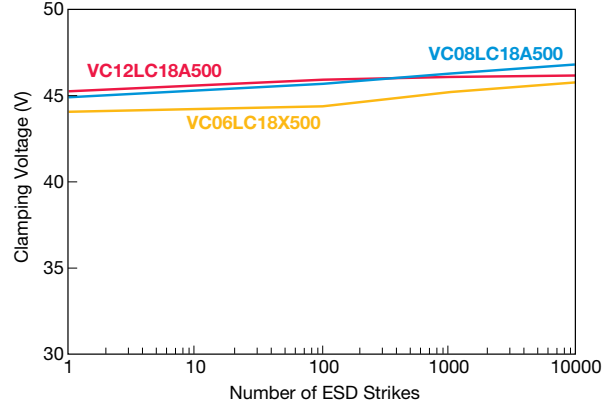

VC08LC18A500 Capacitance Histogram

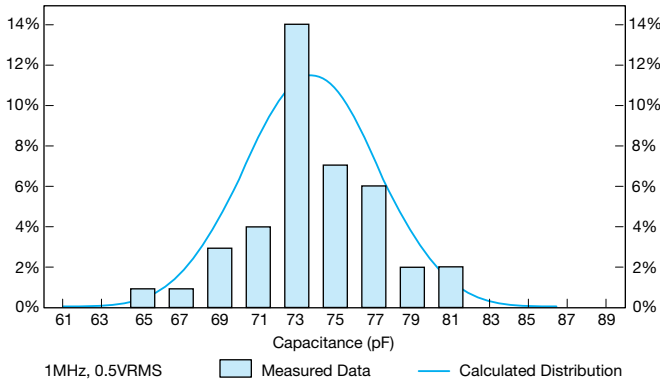

StaticGuard S21

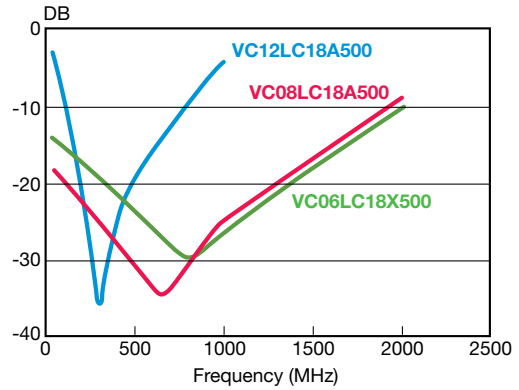

VC12LC18A500 Capacitance Histogram

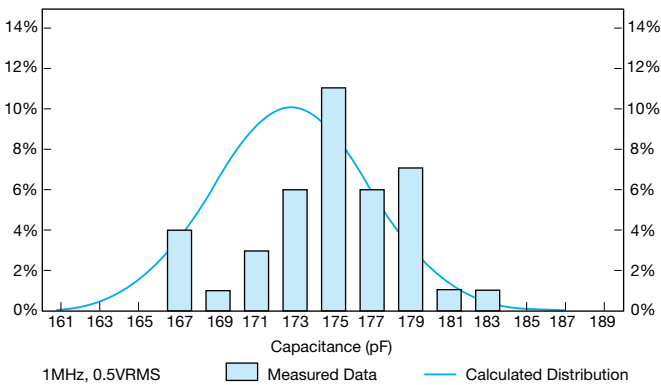

VI Curves - StaticGuard Products

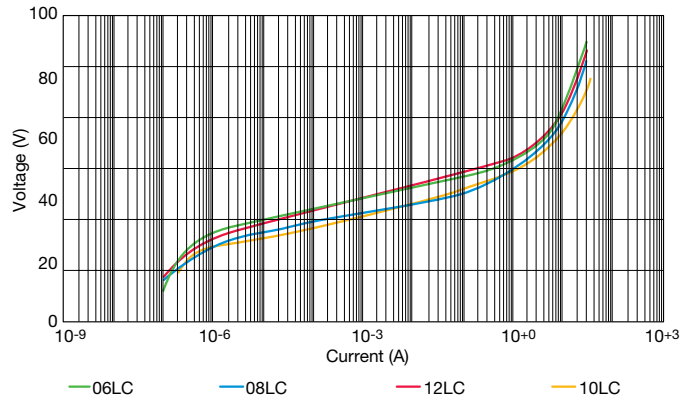

MultiGuard (2 & 4 Elements)

AVX Multilayer Ceramic Transient Voltage Suppression Arrays – ESD Protection for CMOS and Bi Polar Systems



GENERAL DESCRIPTION AND COMMENTS

AVX's Transient Voltage Suppression (TVS) Arrays address six trends in today's electronic circuits: (1) mandatory ESD protection, (2) mandatory EMI control, (3) signal integrity improvement, (4) PCB downsizing, (5) reduced component placement costs, and (6) protection from induced slow speed transient voltages and currents.

AVX's MultiGuard products offer numerous advantages, which include a faster turn-on-time (<1nS), repetitive strike capability, and space savings. In some cases, MultiGuard consumes less than 75% of the PCB real estate required for the equivalent number of discrete chips. This size advantage, coupled with the savings associated with placing only one chip, makes MultiGuard the TVS component of choice for

ESD protection of I/O lines in portable equipment and programming ports in cellular phones. Other applications include differential data line protection, ASIC protection and LCD driver protection for portable computing devices.

Where multiple lines require the ESD protection, the 4-element 0612 or 0508 chip is an ideal solution. While the 2-element 0405 MultiGuard is the smallest TVS array, the 4-element 0508 MultiGuard is the smallest 4-element TVS device available in the market today.

Available with standard working voltage of 5.6V up to 18V with low capacitance in the 3 case sizes, AVX MultiGuard arrays offer a very broad range of integrated TVS solutions to the design community.

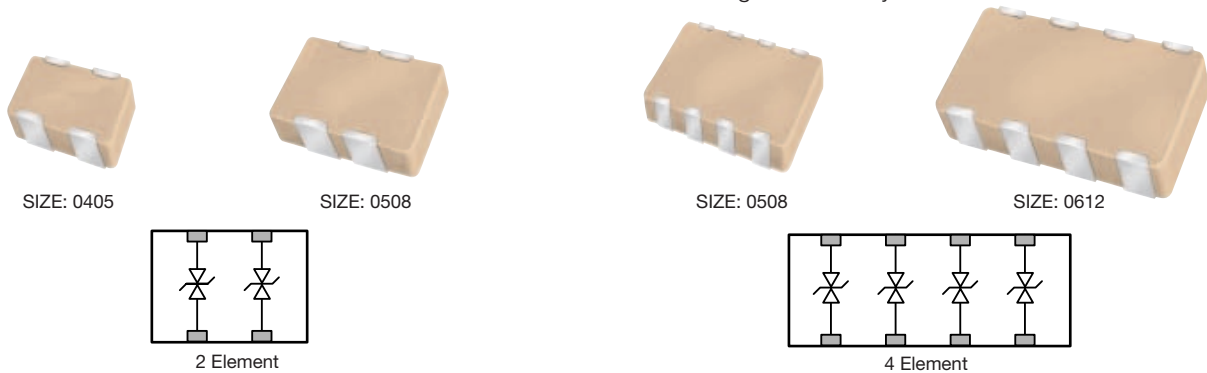

ELECTRICAL CHARACTERISTICS PER ELEMENT

	AVX Part Number	Working Voltage (DC)	Working Voltage (AC)	Breakdown Voltage	Clamping Voltage	Test Current For V_c	Maximum Leakage Current	Transient Energy Rating	Peak Current Rating	Typical Cap
2 Element 0405 Chip	MG042S05X150 __	5.6	4.0	8.5±20%	18	1	35	0.05	15	300
	MG042L14V400 __	14.0	10.0	18.5±12%	32	1	15	0.02	15	45
	MG042L18V500 __	18.0	14.0	N/A	50	1	10	0.02	15	40
2 Element 0508 Chip	MG052S05A150 __	5.6	4.0	8.5±20%	18	1	35	0.10	30	825
	MG052S09A200 __	9.0	6.4	12.7±15%	22	1	25	0.10	30	550
	MG052S14A300 __	14.0	10.0	19.5±12%	32	1	15	0.10	30	425
	MG052S18A400 __	18.0	14.0	25.5±10%	42	1	10	0.10	30	225
	MG052L18X500 __	≤18.0	≤14.0	N/A	50	1	10	0.10	20	50
4 Element 0508 Chip	MG054S05X150 __	5.6	4.0	8.5±20%	18	1	35	0.05	15	400
	MG054S09X200 __	9.0	6.4	12.7±15%	22	1	25	0.05	15	300
	MG054S14X300 __	14.0	10.0	19.5±12%	32	1	15	0.05	15	150
	MG054S18X400 __	18.0	14.0	25.5±10%	42	1	10	0.05	15	120
	MG054L18V500 __	≤18.0	≤14.0	N/A	50	1	10	0.02	15	50
4 Element 0612 Chip	MG064S05A150 __	5.6	4.0	8.5±20%	18	1	35	0.10	30	825
	MG064S09A200 __	9.0	6.4	12.7±15%	22	1	25	0.10	30	550
	MG064S14A300 __	14.0	10.0	19.5±12%	32	1	15	0.10	30	425
	MG064S18A400 __	18.0	14.0	25.5±10%	42	1	10	0.05	15	120
	MG064L18X500 __	≤18.0	≤14.0	N/A	50	1	10	0.10	20	75

Termination Finish Code
Packaging Code

V_w (DC) DC Working Voltage (V)
 V_w (AC) AC Working Voltage (V)
 V_B Typical Breakdown Voltage (V @ 1mA_{DC})
 V_B Tol V_B Tolerance is ± from Typical Value

V_c Clamping Voltage (V @ I_c)
 I_c Test Current for V_c (A, 8x20µS)
 I_l Maximum Leakage Current at the Working Voltage (µA)
 E_T Transient Energy Rating (J, 10x1000µS)
 I_p Peak Current Rating (A, 8x20µS)
 Cap Typical Capacitance (pF) @ 1MHz and 0.5 V_{RMS}



MultiGuard (2 & 4 Elements)



AVX Multilayer Ceramic

Transient Voltage Suppression Arrays

ESD Protection for CMOS and Bi Polar Systems

PHYSICAL DIMENSIONS AND PAD LAYOUT

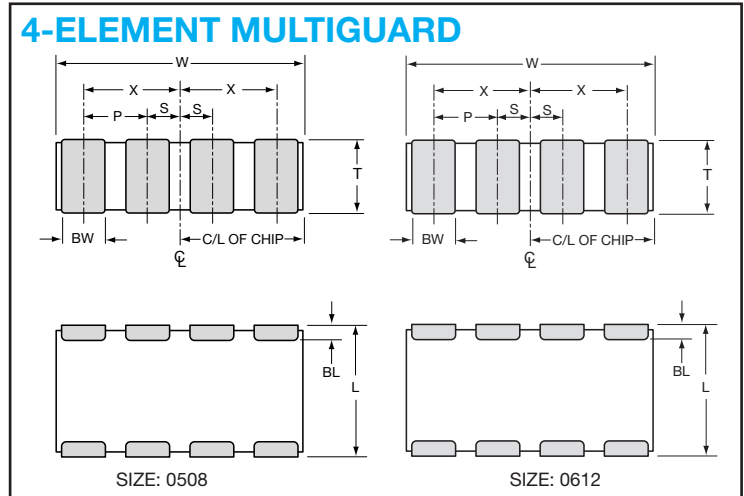
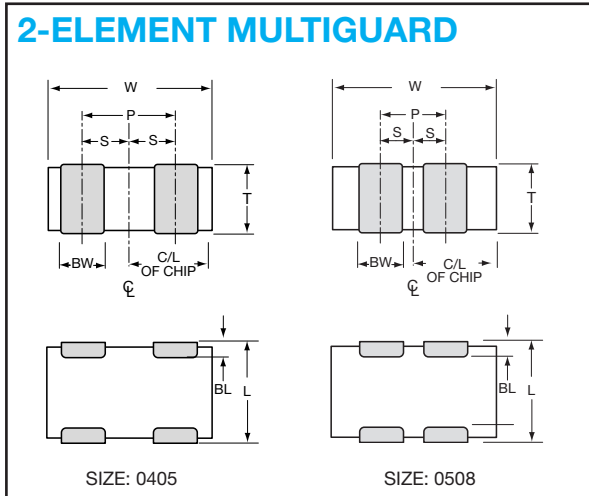

0405 2 Element Dimensions mm (inches)

L	W	T	BW	BL	P	S
1.00±0.15 (0.039±0.006)	1.37±0.15 (0.054±0.006)	0.66 MAX (0.026 MAX)	0.36±0.10 (0.014±0.004)	0.20±0.10 (0.008±0.004)	064 REF (0.025 REF)	0.32±0.10 (0.013±0.004)

0508 4 Element Dimensions mm (inches)

L	W	T	BW	BL	P
1.27±0.20 (0.050±0.008)	2.03±0.20 (0.080±0.008)	0.965 MAX (0.038 MAX)	0.254±0.10 (0.010±0.004)	0.18 ^{+0.25} _{-0.08} (0.007 ^{+0.10} _{-0.003})	0.508 REF (0.020 REF)

0508 2 Element Dimensions mm (inches)

L	W	T	BW	BL	P	S
1.25±0.20 (0.049±0.008)	2.01±0.20 (0.079±0.008)	1.02 MAX (0.040 MAX)	0.41±0.1 (0.016±0.004)	0.18 ^{+0.25} _{-0.08} (0.007 ^{+0.10} _{-0.003})	0.76 REF (0.030 REF)	0.38±0.10 (0.015±0.004)

0612 4 Element Dimensions mm (inches)

L	W	T	BW	BL	P	X	S
1.60±0.20 (0.063±0.008)	3.20±0.20 (0.126±0.008)	1.22 MAX (0.048 MAX)	0.41±0.10 (0.016±0.004)	0.18 ^{+0.25} _{-0.08} (0.007 ^{+0.10} _{-0.003})	0.76 REF (0.030 REF)	1.14±0.10 (0.045±0.004)	0.38±0.10 (0.015±0.004)

Pad Layout Dimensions

A	B	C	D	E
0405 2 Element				
0.46 (0.018)	0.74 (0.029)	1.20 (0.047)	0.38 (0.015)	0.64 (0.025)

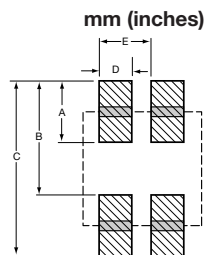

A	B	C	D	E
0508 2 Element				
0.89 (0.035)	1.27 (0.050)	2.16 (0.085)	0.46 (0.018)	0.76 (0.030)

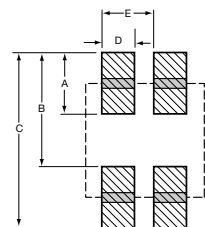

Pad Layout Dimensions

A	B	C	D	E
0508 4 Element				
0.64 (0.025)	1.27 (0.050)	1.91 (0.075)	0.28 (0.011)	0.51 (0.020)

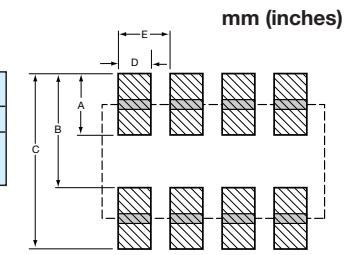

A	B	C	D	E
0612 4 Element				
0.89 (0.035)	1.65 (0.065)	2.54 (0.100)	0.46 (0.018)	0.76 (0.030)

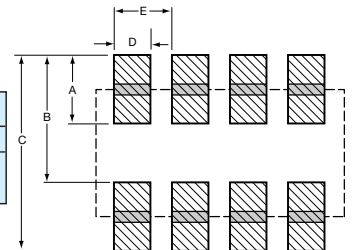

HOW TO ORDER

MG	04	2	L	14	A	300	T	P
MultiGuard	Case Size	Configuration	Style	Working Voltage	Energy Rating	Clamping Voltage	Packaging (PCS/REEL)	Termination Finish
	04 = 0405 05 = 0508 06 = 0612	2 = 2 Elements 4 = 4 Elements	S = Standard Construction L = Low Capacitance	05 = 5.6VDC 09 = 9.0VDC 14 = 14.0VDC 18 = 18.0VDC	A = 0.10 Joules V = 0.02 Joules X = 0.05 Joules	150 = 18V 200 = 22V 300 = 32V 400 = 42V 500 = 50V	D = 1,000 R = 4,000 T = 10,000	P = Ni/Sn Alloy (Plated) M = Ni/Sn Pb (Plated)



MultiGuard (2 & 4 Elements)

AVX Multilayer Ceramic

Transient Voltage Suppression Arrays

ESD Protection for CMOS and Bi Polar Systems



TYPICAL PERFORMANCE CURVES – VOLTAGE/CURRENT CHARACTERISTICS

Multilayer construction and improved grain structure result in excellent transient clamping characteristics in excess of 30 amps (20 amps on MG064L18X500) peak current while maintaining very low leakage currents under DC operating

conditions. The VI curves below show the voltage/current characteristics for the 5.6V, 9V, 14V and 18V parts with currents ranging from fractions of a micro amp to tens of amps.

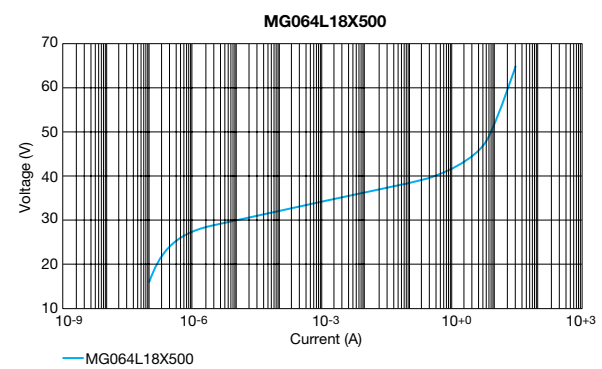
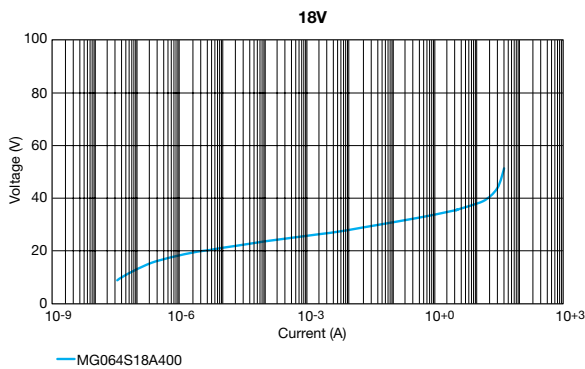
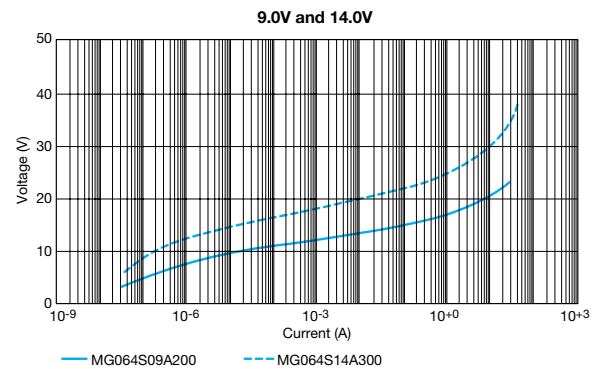
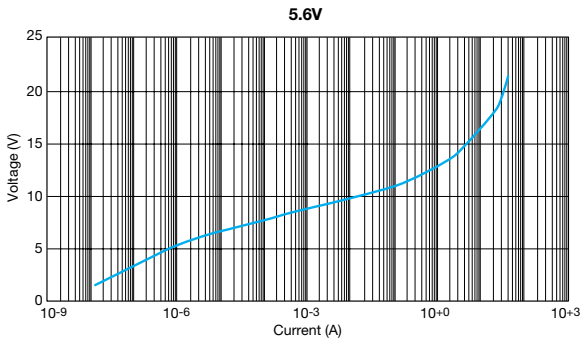

TYPICAL PERFORMANCE CURVES – TEMPERATURE CHARACTERISTICS

MultiGuard suppressors are designed to operate over the full temperature range from -55°C to +125°C.

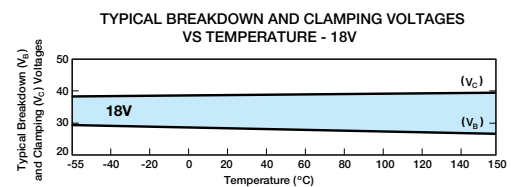
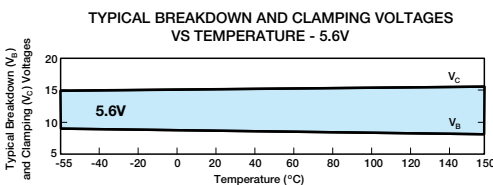
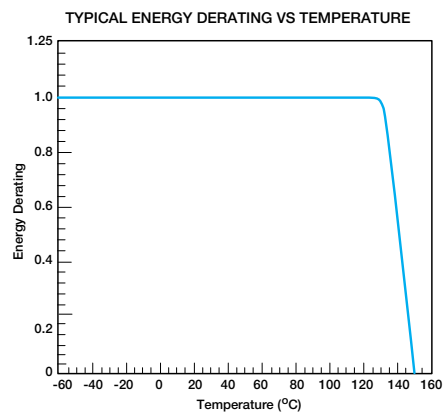
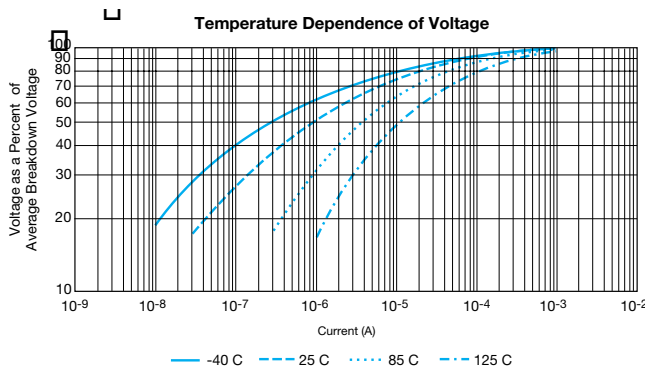

MultiGuard (2 & 4 Elements)

AVX Multilayer Ceramic

Transient Voltage Suppressors Arrays

ESD Protection for CMOS and Bi Polar Systems



TRANSIENT VOLTAGE SUPPRESSORS – TYPICAL PERFORMANCE CURVES

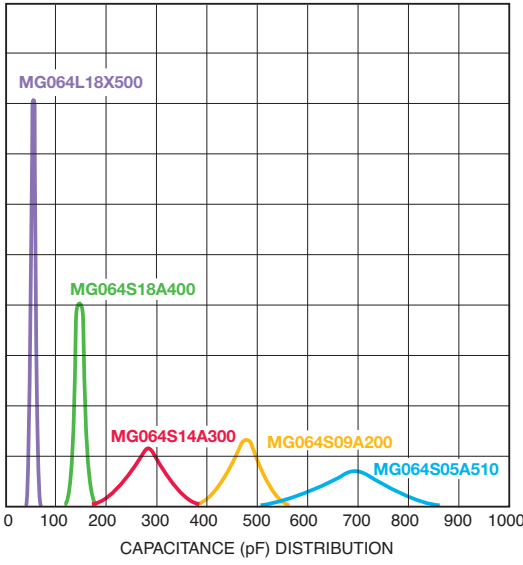
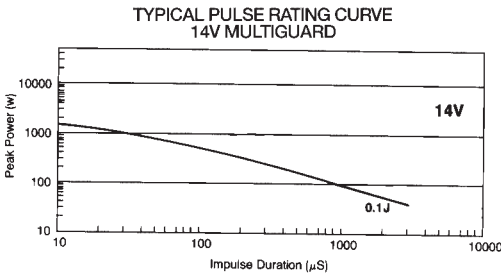
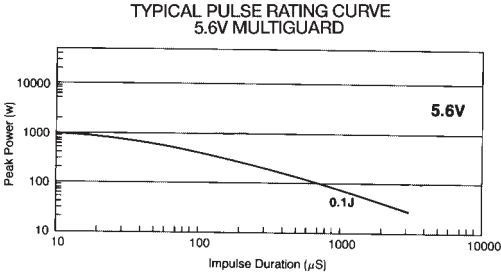

APPLICATION

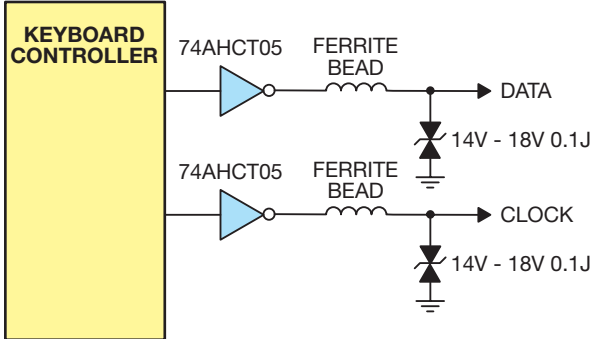
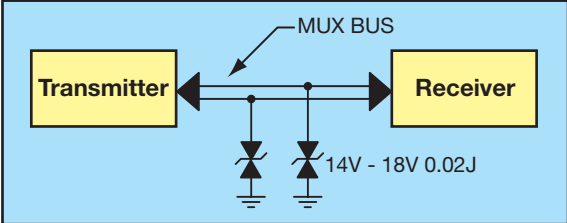

AVX Multilayer Ceramic Transient Voltage Suppressors ESD Protection for Antennas and Low Capacitor Loading Applications

GENERAL DESCRIPTION

RF antenna/RF amplifier protection against ESD events is a growing concern of RF circuit designers today, given the combination of increased signal “gain” demands, coupled with the required downsizing of the transistor package. The ability to achieve both objectives is tied to a reduced thickness of the SiO₂ gate insulator layer within the semiconductor. The corresponding result of such a change increases the Power Amplifier’s (PA’s) vulnerability to ESD strikes — a common event with handheld electronic products with RF transmitting and/or receiving features.

AVX’s 0402/0603 AntennaGuard products are an ultra-low capacitance extension of the proven TransGuard TVS (transient voltage suppression) line of multilayer varistors. RF designers now have a single chip option over conventional protection methods (passive filters with diode clamps), which not only gives superior performance over traditional schemes, but also provides the added benefits of reduced PCB real estate and lower installation costs.

AVX’s AntennaGuard products are available in capacitance ratings of $\leq 3\text{pF}$ (0402 & 0603 chips) and $\leq 12\text{pF}$ (0603 chip). These low capacitance values have low insertion loss, as well as give other TransGuard advantages such as small size, sub-nanosecond response time, low leakage currents and unsurpassed reliability (FIT Rate of 0.2) compared to diodes.

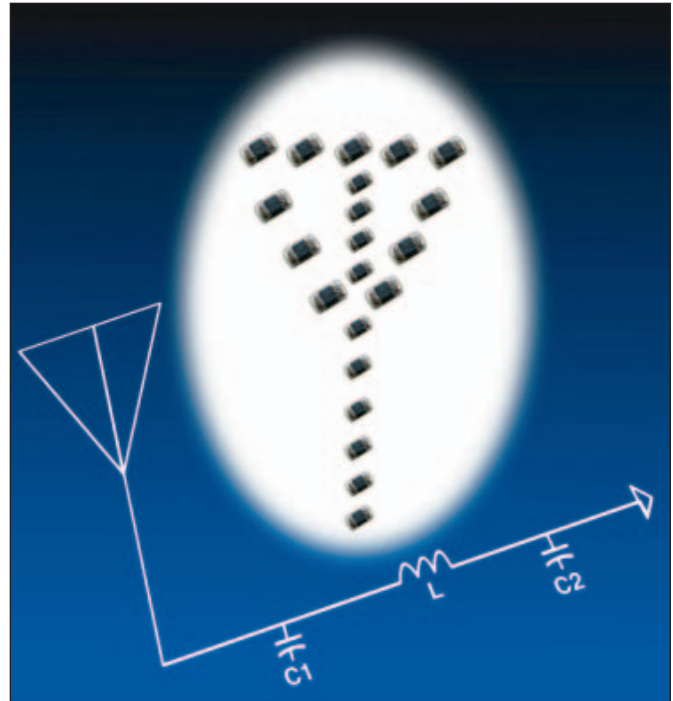

FEATURES

- Smallest TVS Component
- Standard EIA Chip Sizes
- Chip Placement Compatible
- Fastest Response Time to ESD Strikes
- Two Cap Values (≤ 3 and $\leq 12\text{pF}$)

APPLICATION

- ESD Protection for RF Amplifiers
- Laser Drivers

HOW TO ORDER

VC	04	AG	18	3R0	Y	A	T	x	x
Varistor Chip	Chip Size 04 = 0402 06 = 0603	Varistor Series AntennaGuard	Working Voltage (DC)	Capacitance 3pF = 3R0 12pF = 120	Non-Std. Cap Tolerance (Maximum)	Not Applicable	Termination T = Ni/Sn Alloy (Plated) M = Ni/Sn Pb (Plated)	Reel Size 1 = 7" 3 = 13" W = 7" (0402 only)	Reel Quantity A = 4,000 or 10,000 (i.e., 1A = 4,000 3A = 10,000 WA = 10,000)

AntennaGuard 0402/0603



AVX Multilayer Ceramic Transient Voltage Suppressors ESD Protection for Antennas and Low Capacitor Loading Applications

ANTENNAGUARD CATALOG PART NUMBERS/ELECTRICAL VALUES

AVX Part Number	V _w (DC)	V _w (AC)	I _L	Cap	Case Size	Elements
VC04AG183R0YAT__	≤18	≤14	0.1	3	0402	1
VC06AG183R0YAT__	≤18	≤14	0.1	3	0603	1
VC06AG18120YAT__	≤18	≤14	0.1	12	0603	1

Termination Finish Code
Packaging Code

V_w (DC) DC Working Voltage (V)

V_w (AC) AC Working Voltage (V)

I_L Maximum Leakage Current at the Working Voltage (μA)

Cap Maximum Capacitance (pF) @ 1 MHz and 0.5 V_{rms}; VC06AG18120YAT capacitance tolerance: +4, -2pF

PHYSICAL DIMENSIONS

mm (inches)

	0402	0603
Length	1.0 (0.039) ±0.1 (0.004)	1.6 (0.063) ±0.15 (0.006)
Width	0.5 (0.020) ±0.1 (0.004)	0.8 (0.031) ±0.15 (0.006)
Thickness	0.6 Max. (0.024)	0.9 Max. (0.035)
Termination Band Width	0.25 (0.010) ±0.15 (0.006)	0.35 (0.014) ±0.15 (0.006)

AntennaGuard 0402/0603



AVX Multilayer Ceramic Transient Voltage Suppressors ESD Protection for Antennas and Low Capacitor Loading Applications

Antenna Varistors

AVX offers a series of 0402 and 0603 chip varistors, designated the AntennaGuard series, for RF antenna/RF amplifier protection. These devices offer ultra-low capacitance (<3pF in 0402 chips, and $\leq 3\text{pF}$ & $\leq 12\text{pF}$ in 0603 packages), as well as low insertion loss. Antenna varistors can replace output capacitors and provide ESD suppression in cell phones, pagers and wireless LANs.

It is very common to employ some form of a FET in many types of efficient/minature RF amplifiers. Typically, these RF transistors have nearly ideal input gate impedance and outstanding noise figures. However, FETs are very susceptible to ESD damage due to the very thin layer of SiO_2 uses as the gate insulator. The ultra-thin SiO_2 layer is required to improve the gain of the transistor. In other words, the upside of the performance enhancement becomes the downside of the transistors survival when subjected to an ESD event.

ESD damage to the RF Field Effect Transistors (FETs) is a

growing concern among RF designers due to the following trends: (1) RF amplifiers continue to shrink in size, and (2) FET gains figures continue to increase. Both trends relate to decreasing gate oxide thickness, which in turn, is directly proportional to increased ESD sensitivity. As miniaturization trends accelerate, the traditional methods to protect against ESD damage (i.e., PC board layout, passive filters, and diode clamps) are becoming less and less effective.

AVX's AntennaGuard varistor can be used to protect the FET and offer superior performance to the previously mentioned protection methods given above. The standard EIA 0603 chip size, and particularly the 0402 chip, offer designers an ESD protection solution consistent with today's downsizing trend in portable electronic products. Savings in component volume up to 86%, and PC board footprint savings up to 83% are realistic expectations. These percentages are based upon the following table and Figures 1A and 1B.

mm (inches)

Suppression Device	Pad Dimensions				
	D1	D2	D3	D4	D5
AVX 0402 TransGuard	1.70 (0.067)	0.61 (0.024)	0.51 (0.020)	0.61 (0.024)	0.51 (0.020)
AVX 0603 TransGuard	2.54 (0.100)	0.89 (0.035)	0.76 (0.030)	0.89 (0.035)	0.76 (0.030)
Competitor's SOT23 Diode	See Below				

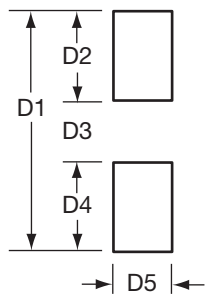

Figure 1A. 0402/0603
IR Solder Pad Layout

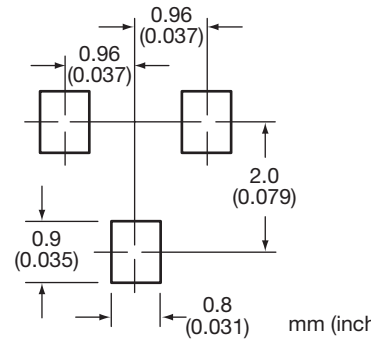

Figure 1B. SOT23- Solder Pad Layout

AntennaGuard 0402/0603



AVX Multilayer Ceramic Transient Voltage Suppressors ESD Protection for Antennas and Low Capacitor Loading Applications

Antenna varistors offer excellent ESD repetitive strike capability compared to a SOT23 diode when subjected to IEC 61000-4-2 8kV contact discharge. A performance summary is shown in Figure 2.

ESD TEST OF ANTENAGUARD RATINGS

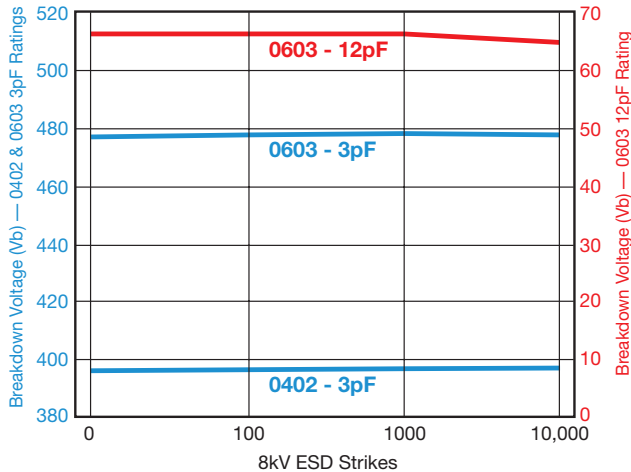

Figure 2. Repetitive 8kV ESD Strike

Antenna varistors also turn on and divert ESD overvoltages at a much faster rate than SOT23 devices (typically 300pS vs 1500pS - 5000pS). See Figure 3.

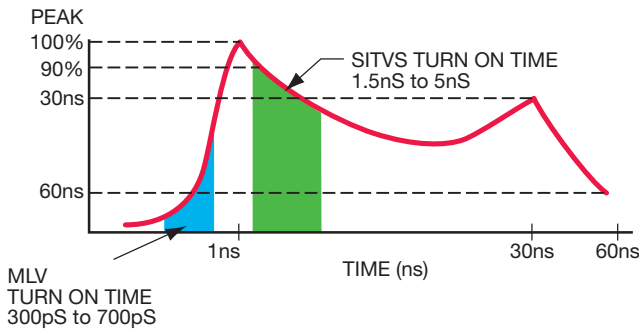

Figure 3. Turn On Time

The equivalent circuit model for a typical antenna varistor is shown in Figure 4.

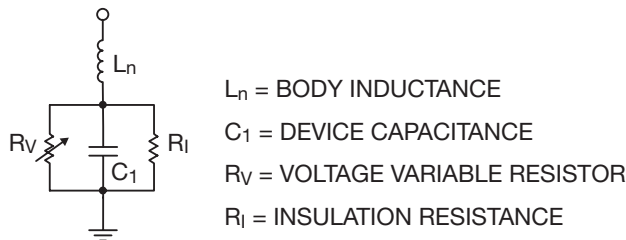

Figure 4. Antenna Varistor

The varistor shown exhibits a capacitance of $\leq 3\text{pF}$ which can be used to replace the parallel capacitance typically found prior to the antenna output of an RF amplifier. In the off state, the varistor acts as a capacitor and helps to filter RF output. The varistor is not affected by RF output power or voltage and has little insertion loss. See Figure 3.

ANTENNA VARISTOR S21

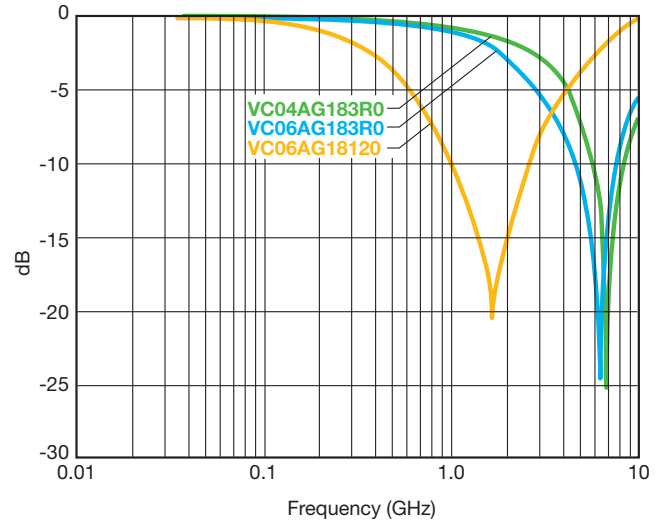

Figure 5. Antenna vs Frequency

Typical implementations of the antenna varistors are shown for use in cell phone, pager and wireless LAN applications in Figures 6A, 6B and 6C.

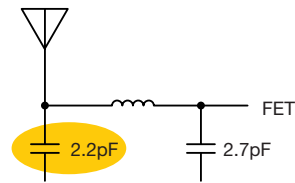

Figure 6A. Cell Phone

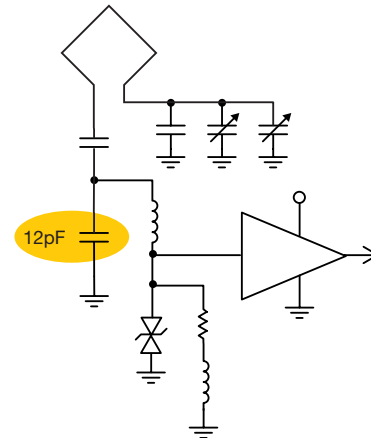

Figure 6B. Pager

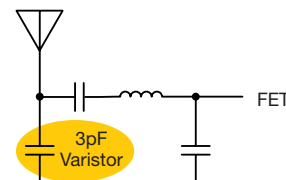

Figure 6C.

USB Series Varistor

Multilayer Varistors for Universal Serial BUS Protection

GENERAL DESCRIPTION

USB Series varistors are designed to protect the high speed data lines against ESD transients. They have very low capacitance and fast turn on times that make this series ideal for data and transmission lines with high data rates. The unique design enables these devices to meet the rigorous testing criteria of the **IEC 61000-4-2** standards. New and improved manufacturing process has created these USB series to be one of the best plated varistors in the market today.

FEATURES

- Zinc Oxide (ZnO) based ceramic semiconductor devices with non-linear voltage-current characteristics
- Bi-directional device, similar to back-to-back Zener diodes plus an EMC capacitor in parallel
- Entire structure made up of conductive ZnO grains surrounded by electrically insulating barriers, creating varistor-like behavior
- Electrical advantages over Zener diodes are repetitive strike capability, high in rush current capability, fast turn-on-time and EMI attenuation
- Protects against ESD to meet **IEC 61000-4-2** 15kV (air) and 8kV (contact)
- Low capacitance for high speed data lines
- Available in discrete and array packages (2, 3 and 4 element)
- Low Clamping Voltage
- Low Operating Voltage
- Response time is < 1ns

MECHANICAL CHARACTERISTICS

- Available in EIA 0603 (Single), 0405 (Dual), 0508 (Triple), and 0612 (Quad) cases
- Plated Tin over Nickel Barrier
- Packaged in Tape & Reel

PART NUMBERING

USB	0001	D	P
Style	Case Size	Packaging Code (Reel Size)	Termination
	0001 = 0603 (Single)	D = 7" (1,000 pcs.)	P = Ni/Sn Alloy (Plated)
	0002 = 0405 (2-Element)	R = 7" (4,000 pcs.)	M = Ni/Sn Pb (Plated)
	0003 = 0508 (3-Element)	T = 13" (10,000 pcs.)	
	0004 = 0612 (4-Element)	W = 7" (10,000 pcs.)	
	0005 = 0402 (Single)	0402 only)	
	0006 = 0402 (Single)		

TYPICAL APPLICATIONS

- USB BUS Lines/Firewire Data BUS Lines
- I/O BUS Lines
- 10/100/1000 Ethernet Transmission Lines
- Video Card Data Lines
- Handheld Devices
- Laptop Computers
- LCD Monitors

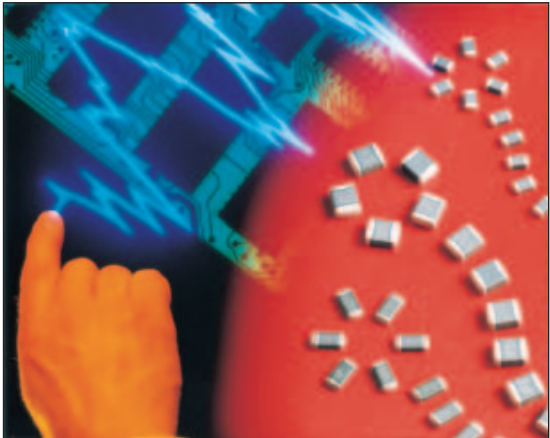

PINOUT CONFIGURATION

USB0001/0005/0006 0603 and 0402 (Single)	
USB0002 0405 (Dual)	
USB0003 0508 (Triple)	
USB0004 0612 (Quad)	

USB Series Varistor



Multilayer Varistors for Universal Serial BUS Protection

RATINGS

Air Discharge ESD	15kV
Contact Discharge ESD	8kV
Operating Temperature	-55°C to +125°C
Soldering Temperature	230°C

PERFORMANCE CHARACTERISTICS

AVX Part No.	V _W (DC)	V _W (AC)	V _B	I _L	E _T	I _P	Cap.	Case Size	Elements
USB0001__	≤18	≤14	120	2	0.015	4	10	0603	1
USB0002__	≤18	≤14	70	2	0.015	4	10	0405	2
USB0003__	≤18	≤14	180	2	0.015	4	10	0508	3
USB0004__	≤18	≤14	100	2	0.015	4	10	0612	4
USB0005__	≤18	≤14	300	2	0.015	4	3	0402	1
USB0006__	≤18	≤14	65	2	0.015	4	6	0402	1

Termination Finish Code
Packaging Code

- V_W(DC) DC Working Voltage (V)
- V_W(AC) AC Working Voltage (V)
- V_B Typical Breakdown Voltage (V @ 1mA_{DC})
- I_L Maximum Leakage Current at the Working Voltage (μA)
- E_T Transient Energy Rating (J, 10x1000μS)
- I_P Peak Current Rating (A, 8x20μS)
- Cap Typical Capacitance (pF) @ 1 MHz and 0.5Vrms

TYPICAL S21 CHARACTERISTICS

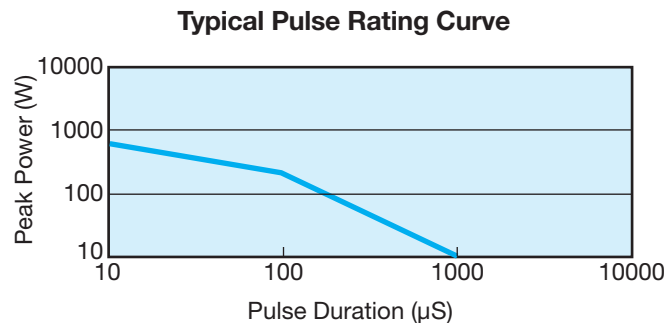
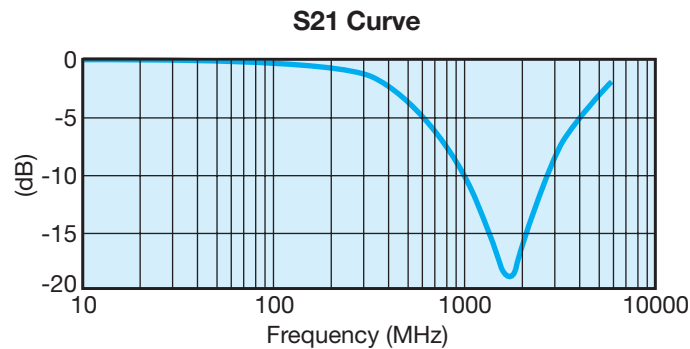

USB Series Varistor



Multilayer Varistors for Universal Serial BUS Protection

PHYSICAL DIMENSIONS AND PAD LAYOUT

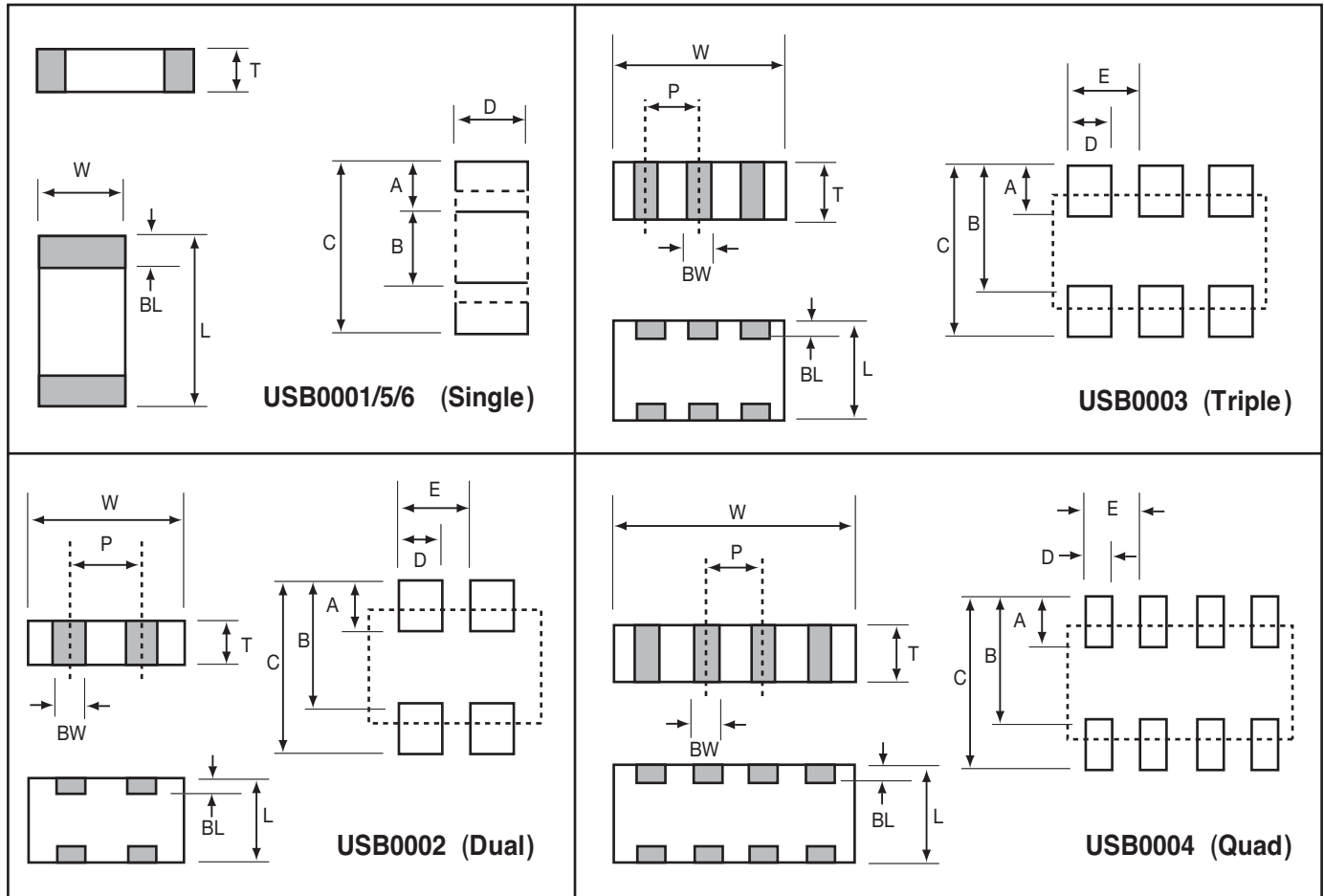

mm (inches)					
L	W	T	BW	BL	P
USB0001					
1.60±0.15 (0.063±0.006)	0.80±0.15 (0.032±0.006)	0.90 Max (0.035 Max.)	N/A	0.35±0.15 (0.014±0.006)	N/A
USB0002					
1.00±0.15 (0.039±0.006)	1.37±0.15 (0.054±0.006)	0.66 Max (0.026 Max.)	0.36±0.10 (0.014±0.004)	0.20±0.10 (0.008±0.004)	0.64 REF (0.025 REF)
USB0003					
1.27±0.20 (0.050±0.008)	2.03±0.20 (0.080±0.008)	0.965 Max (0.038 Max.)	0.254±0.10 (0.010±0.004)	0.18 ^{+0.25/-0.08} (0.007 ^{+0.01/-0.003})	0.64 REF (0.025 REF)
USB0004					
1.60±0.20 (0.063±0.008)	3.20±0.20 (0.126±0.008)	1.22 Max (0.048 Max.)	0.41±0.10 (0.016±0.004)	0.18 ^{+0.25/-0.08} (0.007 ^{+0.01/-0.003})	0.76 REF (0.030 REF)
USB0005 / USB0006					
1.0±0.10 (0.040±0.004)	0.50±0.10 (0.020±0.004)	0.60 Max (0.024 Max.)	N/A	0.25±0.15 (0.010±0.006)	N/A

mm (inches)				
A	B	C	D	E
USB0001				
0.89 (0.035)	0.76 (0.030)	2.54 (0.100)	0.76 (0.030)	N/A
USB0002				
0.46 (0.018)	0.74 (0.029)	1.20 (0.047)	0.30 (0.012)	0.64 (0.025)
USB0003				
0.64 (0.025)	1.27 (0.050)	1.91 (0.075)	0.28 (0.011)	0.51 (0.020)
USB0004				
0.89 (0.035)	1.65 (0.065)	2.54 (0.100)	0.46 (0.018)	0.76 (0.030)
USB0005 / USB0006				
0.61 (0.024)	0.51 (0.020)	1.70 (0.067)	0.51 (0.020)	N/A

USB Series Varistor



Multilayer Varistors for Universal Serial BUS Protection

APPLICATIONS

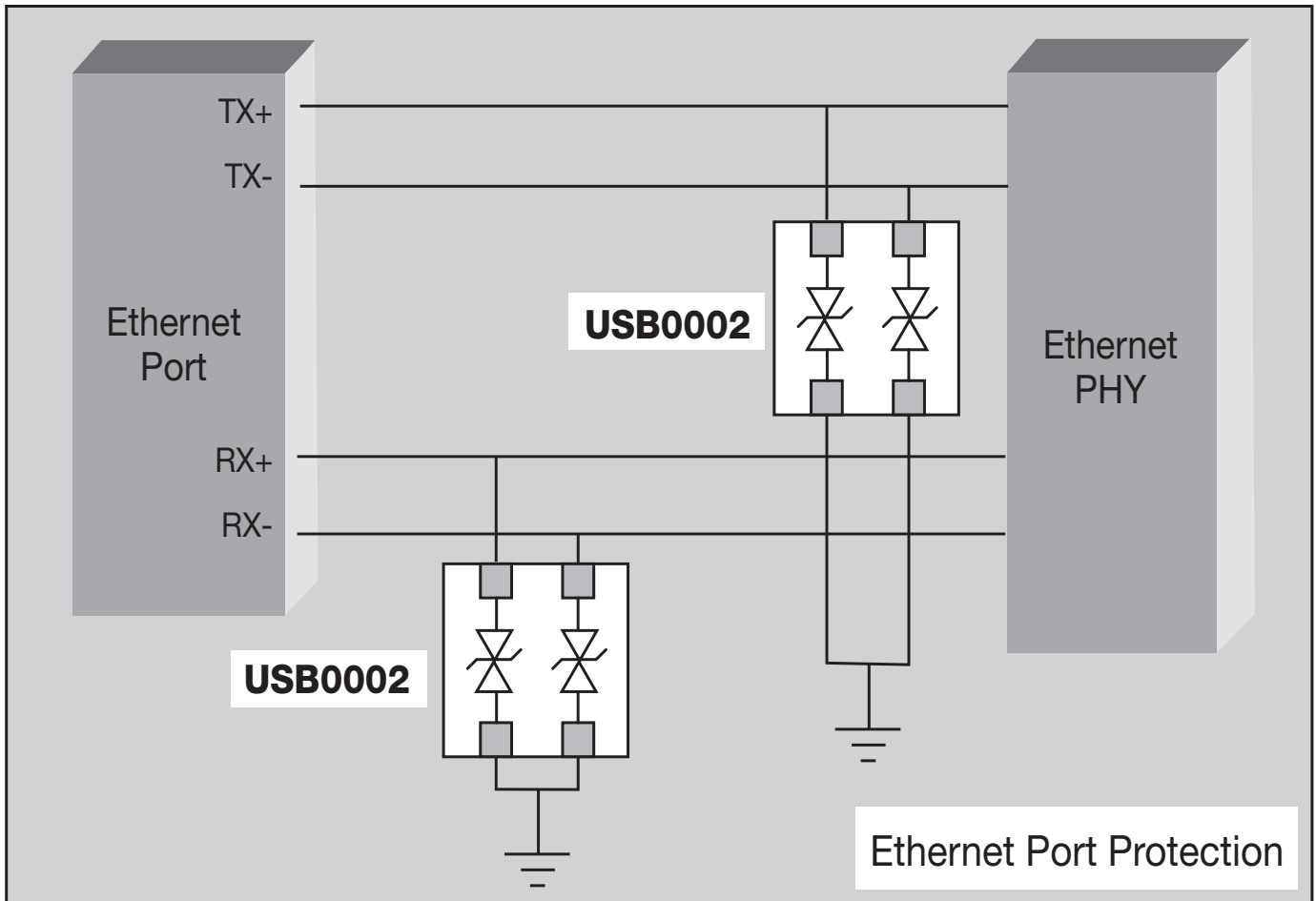
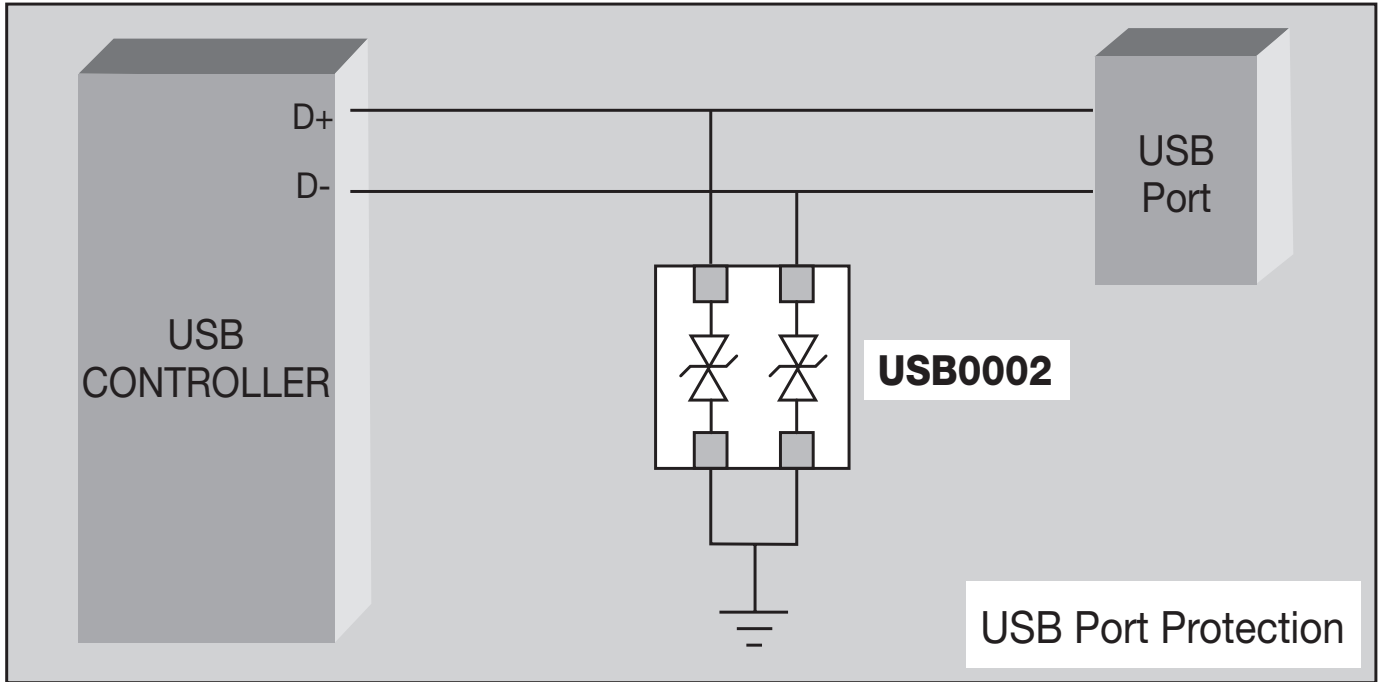

GENERAL DESCRIPTION

The CAN BUS varistor is a zinc oxide (ZnO) based ceramic semiconductor device with non-linear voltage-current characteristics (bi-directional) similar to back-to-back Zener diodes and an EMC capacitor in parallel (see equivalent circuit model). They have the added advantage of greater current and energy handling capabilities as well as EMI/RFI attenuation. Devices are fabricated by a ceramic sintering process that yields a structure of conductive ZnO grains surrounded by electrically insulating barriers, creating varistor like behavior.

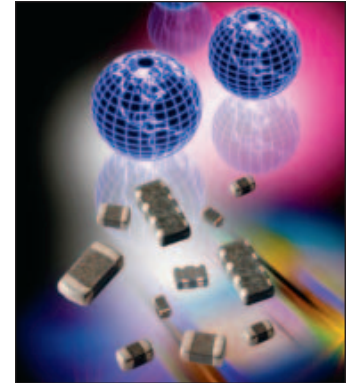

HOW TO ORDER

CAN	0001	D	P
Style	Case Size	Packaging Code (Reel Size)	Termination
Controlled Area Network Varistor Series	0001 = 0603 Discrete 0002 = 0405 2-Element 0004 = 0612 4-Element	D = 7" reel (1,000 pcs.) R = 7" reel (4,000 pcs.) T = 13" reel (10,000 pcs.)	P = Ni/Sn Alloy (Plated) M = Ni/Sn Pb (Plated)

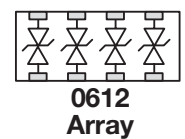
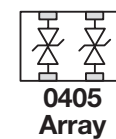

PERFORMANCE CHARACTERISTICS

AVX Part No.	V _W (DC)	V _W (AC)	V _B	I _L	E _T	I _P	Cap.	Case Size	Elements
CAN0001__	≤18	≤14	120	2	0.015	4	22	0603	1
CAN0002__	≤18	≤14	70	2	0.015	4	22	0405	2
CAN0004__	≤18	≤14	100	2	0.015	4	22	0612	4

Termination Finish Code
Packaging Code

- V_W(DC) DC Working Voltage (V)
- V_W(AC) AC Working Voltage (V)
- V_B Typical Breakdown Voltage (V @ 1mA_{DC})
- V_C Clamping Voltage (V @ I_{VC})
- I_{VC} Test Current for V_C (A, 8x20μS)
- I_L Maximum Leakage Current at the Working Voltage (μA)
- E_T Transient Energy Rating (J, 10x1000μS)
- I_P Peak Current Rating (A, 8x20μS)
- Cap Maximum Capacitance (pF) @ 1 MHz and 0.5Vrms

EQUIVALENT CIRCUIT MODEL

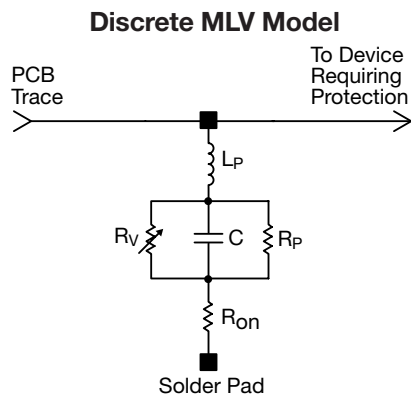

- Where:
- R_V = Voltage Variable resistance (per VI curve)
 - R_p ≥ 10¹² Ω
 - C = defined by voltage rating and energy level
 - R_{on} = turn on resistance
 - L_p = parallel body inductance

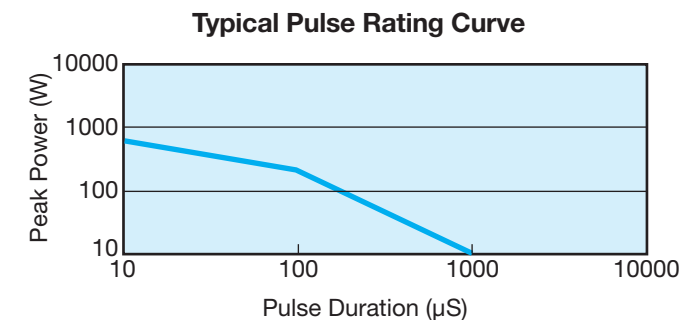
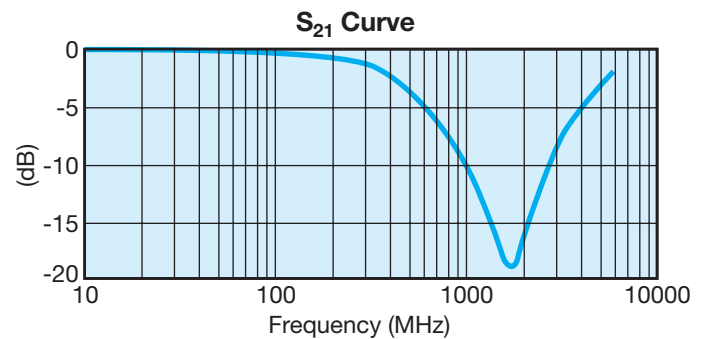

UltraGuard Series



ESD Protection for Low Leakage Requirements

GENERAL DESCRIPTION

As clock speeds and an increasing reliance on batteries as power sources have increased, there is a need for varistors that exhibit very low leakage current. The new series of AVX Transient Voltage Suppressors address this need.

This series provides a transient protection solution for high clock speed integrated circuits, backlit display, medical/instrument applications, power conversion circuits and power supervisory chip sets. In addition, the low leakage characteristics are also suitable for optic circuits like fiber optic transmitters.

The series includes discrete chips (0402, 0603, and 0805), 2-element packages (0405 and 0508), and 4-element packages (0612).



Discrete Chips
0402, 0603,
and 0805

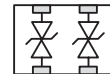

2-Element Arrays
(0405 and 0508)

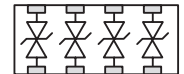

4-Element Arrays
(0612)

HOW TO ORDER

VC
VC=Surface
Mount Chip

UG
Series
UG = Low
Leakage
Series

04
Case Size
04 = 0402
06 = 0603
08 = 0805

0150
**Maximum
Working
Voltage**
0030 = 3.0V_{bc}
0050 = 5.0V_{bc}
0075 = 7.5V_{bc}
0100 = 10.0V_{bc}
0150 = 15.0V_{bc}

L
Capacitance
L = Low
H = High

1
**No. of
Elements**

W
**Packaging
(pieces per
reel)**
D = 1,000
(7" reel)
R = 4,000
(7" reel)
T = 10,000
(13" reel)
W = 10,000
(7" reel,
0402 only)

P
**Termination
Finish**
P = Ni/Sn Alloy
(Plated)
M = Ni/Sn Pb (Plated)

HOW TO ORDER

MG
MG=Array

UG
Series
UG = Low
Leakage
Series

06
Case Size
04 = 0405
05 = 0508
06 = 0612

0150
**Maximum
Working
Voltage**
0030 = 3.0V_{bc}
0050 = 5.0V_{bc}
0075 = 7.5V_{bc}
0100 = 10.0V_{bc}
0150 = 15.0V_{bc}

L
Capacitance
L = Low
H = High

4
**No. of
Elements**
2 = 2 Elements
4 = 4 Elements

D
**Packaging
(pieces per
reel)**
D = 1,000
(7" reel)
R = 4,000
(7" reel)
T = 10,000
(13" reel)

P
**Termination
Finish**
P = Ni/Sn Alloy
(Plated)
M = Ni/Sn Pb (Plated)

ESD Protection for Low Leakage Requirements

AVX Part Number	V _{CIR} (DC)	V _{CIR} (AC)	Cap Required	Cap	Freq	I _L	Case Size	Elements
MGUG040030L2 __	≤3.0	≤2.3	Low	300	M	2	0405	2
MGUG050030L2 __	≤3.0	≤2.3	Low	425	M	2	0508	2
MGUG060030L4 __	≤3.0	≤2.3	Low	425	M	2	0612	4
VCUG040030L1 __	≤3.0	≤2.3	Low	175	M	2	0402	1
VCUG060030L1 __	≤3.0	≤2.3	Low	750	K	2	0603	1
VCUG080030H1 __	≤3.0	≤2.3	High	3000	K	2	0805	1
VCUG080030L1 __	≤3.0	≤2.3	Low	1100	K	2	0805	1
VCUG120030H1 __	≤3.0	≤2.3	High	3000	K	2	1206	1
VCUG120030L1 __	≤3.0	≤2.3	Low	1200	K	2	1206	1
MGUG040050L2 __	≤5.0	≤3.5	Low	40	M	2	0405	2
MGUG050050L2 __	≤5.0	≤3.5	Low	425	M	2	0508	2
MGUG060050L4 __	≤5.0	≤3.5	Low	425	M	2	0612	4
VCUG040050L1 __	≤5.0	≤3.5	Low	175	M	2	0402	1
VCUG060050L1 __	≤5.0	≤3.5	Low	550	K	2	0603	1
VCUG080050L1 __	≤5.0	≤3.5	Low	750	K	2	0805	1
VCUG120050H1 __	≤5.0	≤3.5	High	1050	K	2	1206	1
VCUG120050L1 __	≤5.0	≤3.5	Low	600	K	2	1206	1
MGUG040075L2 __	≤7.5	≤5.3	Low	40	M	2	0405	2
MGUG050075L2 __	≤7.5	≤5.3	Low	425	M	2	0508	2
MGUG060075L4 __	≤7.5	≤5.3	Low	425	M	2	0612	4
VCUG040075L1 __	≤7.5	≤5.3	Low	100	M	2	0402	1
VCUG060075L1 __	≤7.5	≤5.3	Low	425	K	2	0603	1
VCUG080075H1 __	≤7.5	≤5.3	High	900	K	2	0805	1
VCUG080075L1 __	≤7.5	≤5.3	Low	325	K	2	0805	1
VCUG120075H1 __	≤7.5	≤5.3	High	1050	K	2	1206	1
VCUG120075L1 __	≤7.5	≤5.3	Low	600	K	2	1206	1
MGUG040100L2 __	≤10.0	≤7.1	Low	40	M	2	0405	2
MGUG050100L2 __	≤10.0	≤7.1	Low	225	M	2	0508	2
MGUG060100L4 __	≤10.0	≤7.1	Low	225	M	2	0612	4
VCUG040100L1 __	≤10.0	≤7.1	Low	65	M	2	0402	1
VCUG060100L1 __	≤10.0	≤7.1	Low	250	K	2	0603	1
VCUG080100H1 __	≤10.0	≤7.1	High	550	K	2	0805	1
VCUG080100L1 __	≤10.0	≤7.1	Low	225	K	2	0805	1
VCUG120100H1 __	≤10.0	≤7.1	High	900	K	2	1206	1
VCUG120100L1 __	≤10.0	≤7.1	Low	350	K	2	1206	1
MGUG040150L2 __	≤15.0	≤11	Low	50	M	2	0405	2
MGUG050150L2 __	≤15.0	≤11	Low	50	M	2	0508	2
MGUG060150L4 __	≤15.0	≤11	Low	75	M	2	0612	4
VCUG040150L1 __	≤15.0	≤11	Low	40	M	2	0402	1
VCUG060150L1 __	≤15.0	≤11	Low	155	K	2	0603	1
VCUG080150H1 __	≤15.0	≤11	High	250	K	2	0805	1
VCUG080150L1 __	≤15.0	≤11	Low	120	K	2	0805	1
VCUG120150H1 __	≤15.0	≤11	High	500	K	2	1206	1

L Termination Finish Code
 — Packaging Code

- V_{CIR}(DC) DC Circuit Voltage (V)
- V_{CIR}(AC) AC Circuit Voltage (V)
- Cap Req Standard or Low
- I_L Maximum Leakage Current at the Circuit Voltage (μA)
- Cap Typical Capacitance (pF) @ frequency specified and 0.5 Vrms
- Freq Frequency at which capacitance is measured (K = 1kHz, M = 1MHz)

ESD Protection for Low Leakage Requirements

PHYSICAL DIMENSIONS

mm (inches)

	0402 Discrete	0603 Discrete	0805 Discrete
Length	1.00 ±0.10 (0.040 ±0.004)	1.60 ±0.15 (0.063 ±0.006)	2.01 ±0.20 (0.079 ±0.008)
Width	0.50 ±0.10 (0.020 ±0.004)	0.80 ±0.15 (0.032 ±0.006)	1.25 ±0.20 (0.049 ±0.008)
Thickness	0.60 Max. (0.024 Max.)	0.90 Max. (0.035 Max.)	1.02 Max. (0.040 Max.)
Term Band Width	0.25 ±0.15 (0.010 ±0.006)	0.35 ±0.15 (0.014 ±0.006)	0.71 Max. (0.028 Max.)

	0405 Array	0508 Array	0612 Array
Length	1.00 ±0.15 (0.039 ±0.006)	1.25 ±0.20 (0.049 ±0.008)	1.60 ±0.20 (0.063 ±0.008)
Width	1.37 ±0.15 (0.054 ±0.006)	2.01 ±0.20 (0.079 ±0.008)	3.20 ±0.20 (0.126 ±0.008)
Thickness	0.66 Max. (0.026 Max.)	1.02 Max. (0.040 Max.)	1.22 Max. (0.048 Max.)
Term Band Width	0.36 ±0.10 (0.014 ±0.004)	0.41 ±0.10 (0.016 ±0.004)	0.41 ±0.10 (0.016 ±0.004)

SOLDER PAD DIMENSIONS

mm (inches)

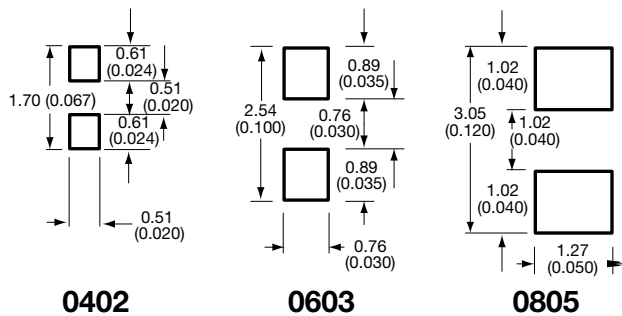

0612 4-Element Array

A	B	C	D	E
0.89 (0.035)	1.65 (0.065)	2.54 (0.100)	0.46 (0.018)	0.76 (0.030)

2-Element Arrays

	A	B	C	D	E
0405	0.46 (0.018)	0.74 (0.029)	1.20 (0.047)	0.38 (0.015)	0.64 (0.025)
0508	0.89 (0.035)	1.27 (0.050)	2.16 (0.085)	0.46 (0.018)	0.76 (0.030)

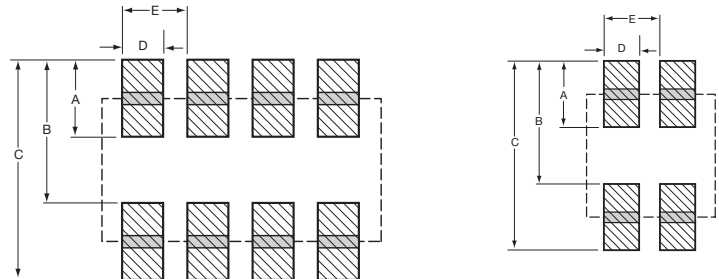

TransFeed

AVX Multilayer Ceramic Transient Voltage Suppressors TVS Protection and EMI Attenuation in a Single Chip

GENERAL DESCRIPTION

AVX has combined the best electrical characteristics of its TransGuard Transient Voltage Suppressors (TVS) and its Feedthru Capacitors into a single chip for state-of-the-art overvoltage circuit protection and EMI reduction over a broad range of frequencies. This unique combination of multilayer ceramic construction in a feedthru configuration gives the circuit designer a single 0805 chip that responds to transient events faster than any TVS device on the market today, and provides significant EMI attenuation when in the off-state.

The reduction in parallel inductance, typical of the feedthru chip construction when compared to the construction of standard TVS or ceramic capacitor chips, gives the TransFeed product two very important electrical advantages: (1) faster “turn-on” time. Calculated response times of <200 pSec are not unusual with this device, and measured response times range from 200 – 250 pSec. The TransFeed “turn-on” characteristic is less than half that of an equivalent TransGuard part — and TransGuards clamp transient voltages faster than any other bipolar TVS solution such as diodes; (2) the second electrical advantage of lower parallel inductance, coupled with optimal series inductance, is the enhanced attenuation characteristics of the TransFeed product. Not only is there significantly greater attenuation at a higher self-resonance frequency, but the roll-off characteristic becomes much flatter, resulting in EMI filtering over a much broader frequency spectrum. Typical applications include filtering/protection on Microcontroller I/O Lines, Interface I/O Lines, Power Line Conditioning and Power Regulation.

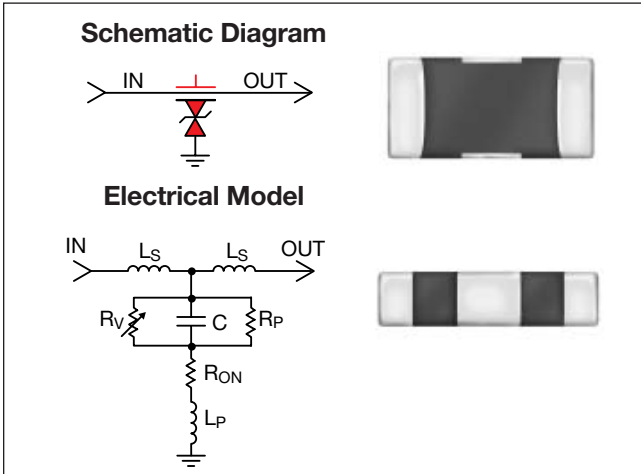

TYPICAL APPLICATIONS

- Fingerprint ID Circuit
- Magnetic Field Circuit
- LCD Dashboard Driver

Where designers are concerned with both transient voltage protection and EMI attenuation, either due to the electrical performance of their circuits or due to required compliance to specific EMC regulations, the TransFeed product is an ideal choice.

HOW TO ORDER

V	2	F	1	05	A	150	Y	2	E	D	P
Varistor	Chip Size	Feedthru Capacitor	No. of Elements	Voltage	Energy Rating	Varistor Clamping Voltage	Capacitance Tolerance	DC Resistance	Feedthru Current	Packaging Code Pcs./Reel	Termination Finish
	2 = 0805 3 = 0612			05 = 5.6VDC 09 = 9.0VDC 14 = 14.0VDC 18 = 18.0VDC	X = 0.05J A = 0.1J C = 0.3J	150 = 18V 200 = 22V 300 = 32V 400 = 42V 500 = 50V	Y = +100/-50%	1 = 0.150 Ohms 2 = 0.200 Ohms 3 = 0.250 Ohms	D = 500 mA E = 750 mA F = 1.0 Amp	D = 1,000 R = 4,000 T = 10,000	P = Ni/Sn Alloy (Plated) M = Ni/Sn Pb (Plated)

TransFeed

AVX Multilayer Ceramic Transient Voltage Suppressors TVS Protection and EMI Attenuation in a Single Chip



TRANSFEED ELECTRICAL SPECIFICATIONS

AVX Part Number	Working Voltage (DC)	Working Voltage (AC)	Breakdown Voltage	Clamping Voltage	Maximum Leakage Current	Transient Energy Rating	Peak Current Rating	Typical Cap	DC Resistance	Maximum Feedthru Current
V2F105A150Y2E __	5.6	4.0	8.5±20%	18	35	0.10	30	800	0.200	0.75
V2F105C150Y1F __	5.6	4.0	8.5±20%	18	35	0.30	120	2500	0.150	1.00
V2F109A200Y2E __	9.0	6.4	12.7±15%	22	25	0.10	30	575	0.200	0.75
V2F109C200Y1F __	9.0	6.4	12.7±15%	22	25	0.30	120	1800	0.150	1.00
V2F114A300Y2E __	14.0	10.0	18.5±12%	32	15	0.10	30	300	0.200	0.75
V2F114C300Y1F __	14.0	10.0	18.5±12%	32	15	0.30	120	900	0.150	1.00
V2F118A400Y2E __	18.0	13.0	25.5±10%	42	10	0.10	30	200	0.200	0.75
V2F118C400Y1F __	18.0	13.0	25.5±10%	42	10	0.30	120	500	0.150	1.00
V2F118X500Y3D __	18.0	13.0	25.5±10%	50	10	0.05	20	75	0.250	0.50
V3F418A400Y3G __	18.0	13.0	25.5±10%	42	10	0.10	20	150	0.200	0.30
V3F418X500Y3G __	18.0	13.0	25.5±10%	50	10	0.05	15	65	0.250	0.20

Termination Finish Code
Packaging Code

- V_w (DC) DC Working Voltage (V)
- V_w (AC) AC Working Voltage (V)
- V_B Typical Breakdown Voltage (V @ $1mA_{DC}$)
- V_B Tol V_B Tolerance is \pm from Typical Value
- V_C Clamping Voltage (V @ 1A $8 \times 20\mu S$)
- I_L Maximum Leakage Current at the Working Voltage (μA)
- E_T Transient Energy Rating (J, $10 \times 1000\mu S$)
- I_P Peak Current Rating (A, $8 \times 20\mu S$)
- Cap Typical Capacitance (pF) @ 1MHz and 0.5 V
- DCR DC Resistance (Ohms)
- I_{FT} Maximum Feedthru Current (A)

dB Attenuation vs Frequency

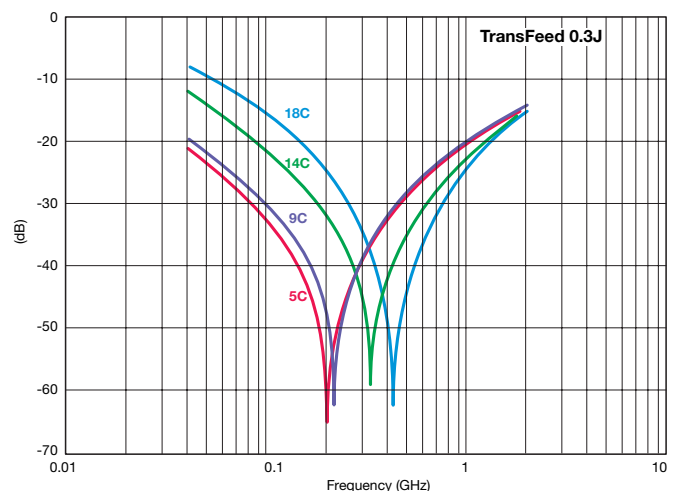
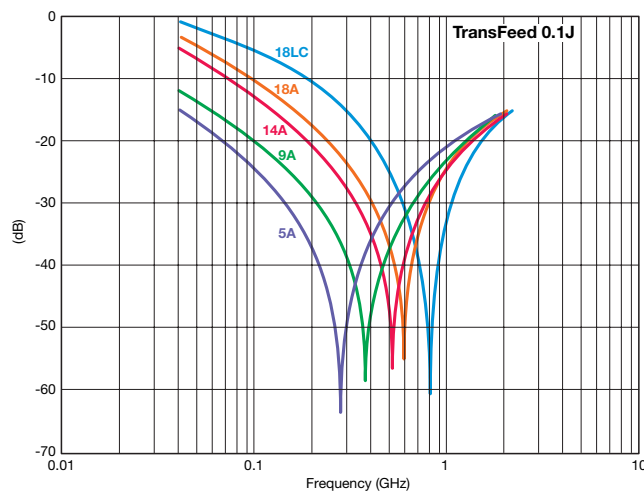

TransFeed

AVX Multilayer Ceramic Transient Voltage Suppressors TVS Protection and EMI Attenuation in a Single Chip



DIMENSIONS

mm (inches)

	L	W	T	BW	BL	EW	X	S
0805	2.01 ± 0.20 (0.079 ± 0.008)	1.25 ± 0.20 (0.049 ± 0.008)	1.143 Max. (0.045 Max.)	0.46 ± 0.10 (0.018 ± 0.004)	0.18 + 0.25 - 0.08 (0.007 + 0.010 - 0.003)	0.25 ± 0.13 (0.010 ± 0.005)	1.02 ± 0.10 (0.040 ± 0.004)	0.23 ± 0.05 (0.009 ± 0.002)

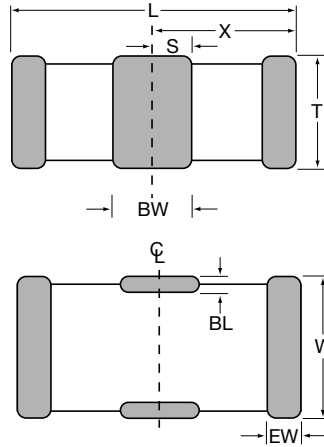

RECOMMENDED SOLDER PAD LAYOUT (Typical Dimensions)

mm (inches)

	T	P	S	W	L	C
0805	3.45 (0.136)	0.51 (0.020)	0.76 (0.030)	1.27 (0.050)	1.02 (0.040)	0.46 (0.018)

4 Pad Layout

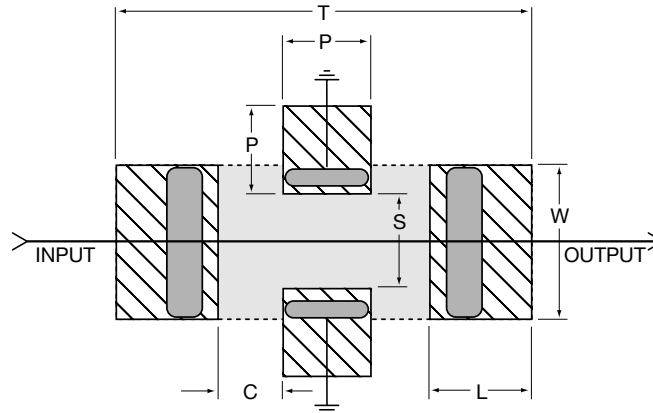

TransFeed Array - V3F4 Series



TVS Protection and EMI Attenuation in a 4-Element Array

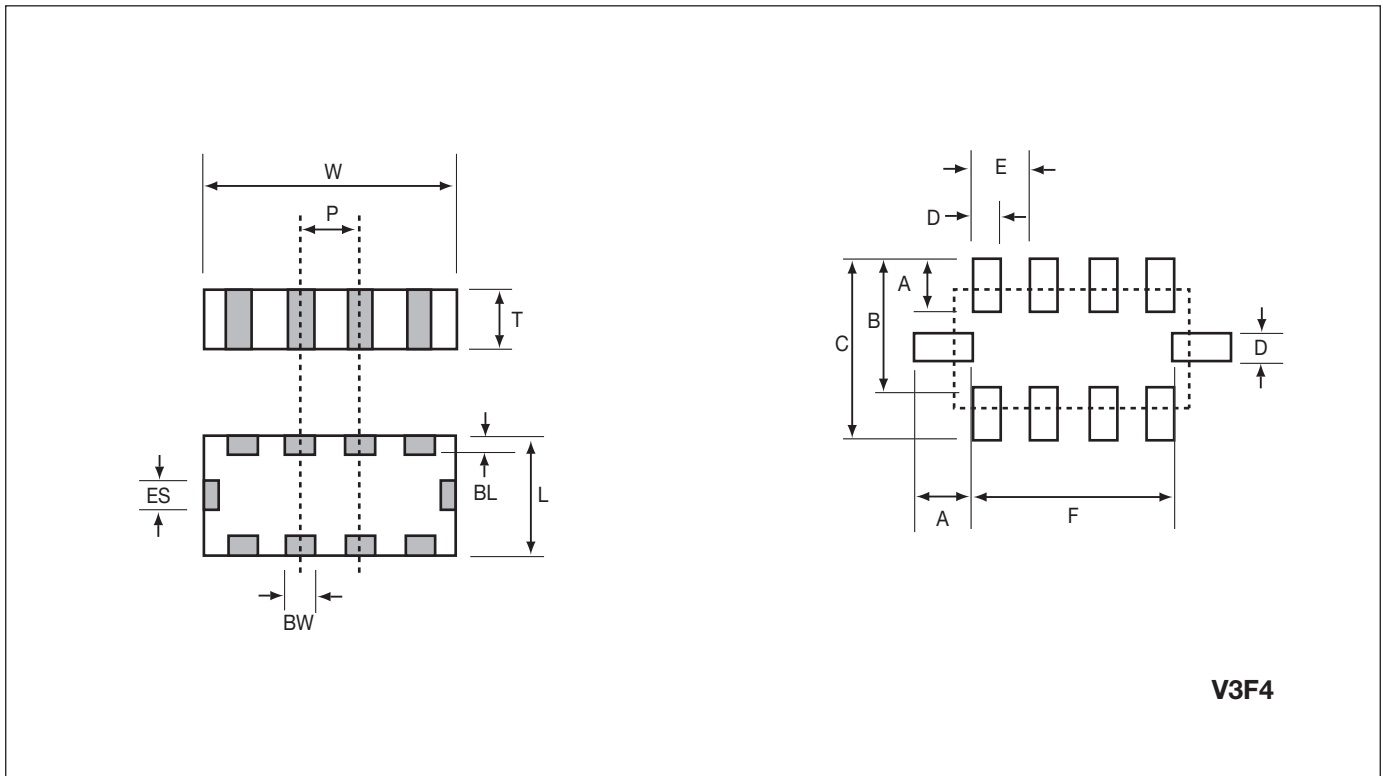

V3F4

DIMENSIONS

mm (inches)

L	W	T	BW	BL	ES	P
1.60 ± 0.20 (0.063 ± 0.008)	3.25 ± 0.15 (0.128 ± 0.006)	1.22 Max. (0.048 Max.)	0.41 ± 0.10 (0.016 ± 0.004)	0.18 +0.25 -0.08 (0.007 +0.010 -0.003)	0.41 ± 0.10 (0.016 ± 0.004)	0.76 REF (0.030 REF)

mm (inches)

A	B	C	D	E	F
0.60 (0.024)	1.60 (0.064)	2.20 (0.088)	0.35 (0.014)	0.76 (0.030)	2.60 (0.104)

PERFORMANCE CHARACTERISTICS

INSERTION LOSS COMPARISON (TransFeed vs TransGuard)

0805 – dB vs Frequency

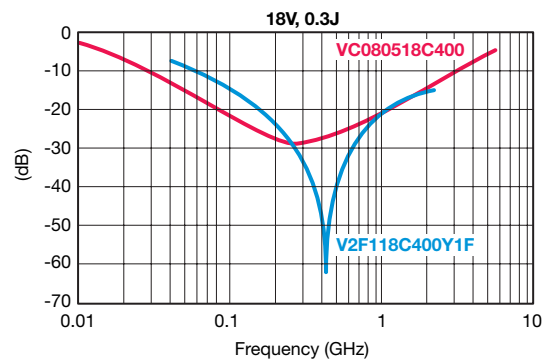
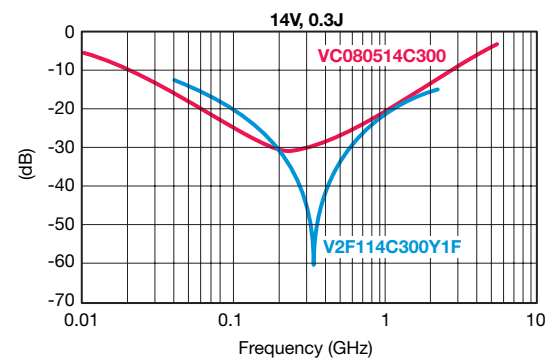
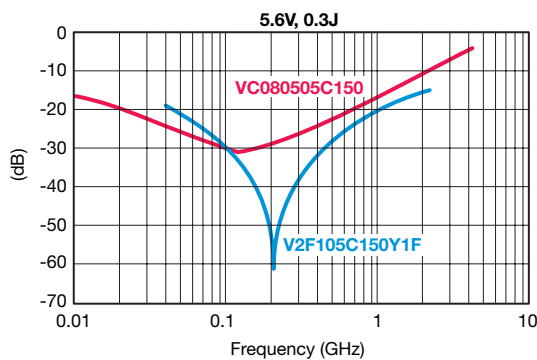
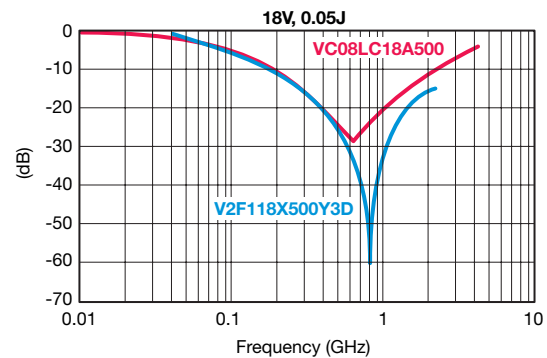
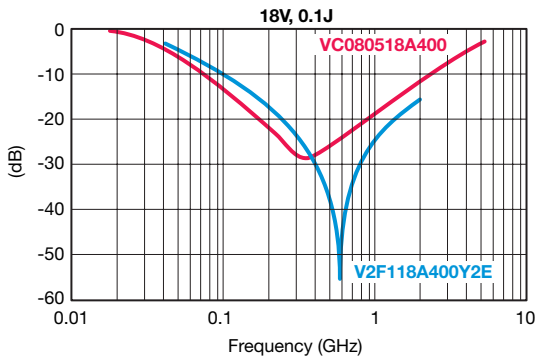
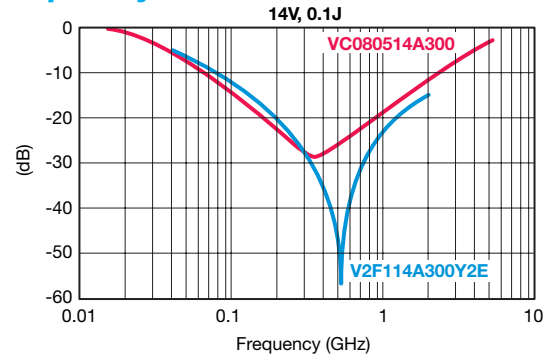
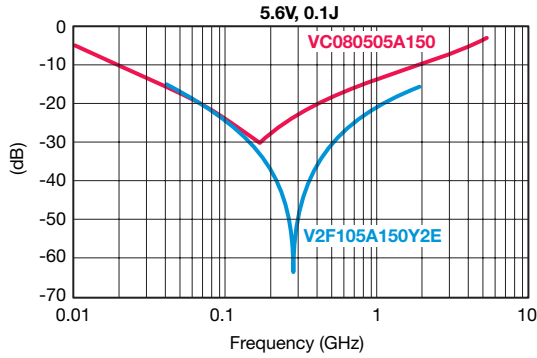

PERFORMANCE CHARACTERISTICS

CURRENT vs TEMPERATURE

0805 – 0.1 Joule

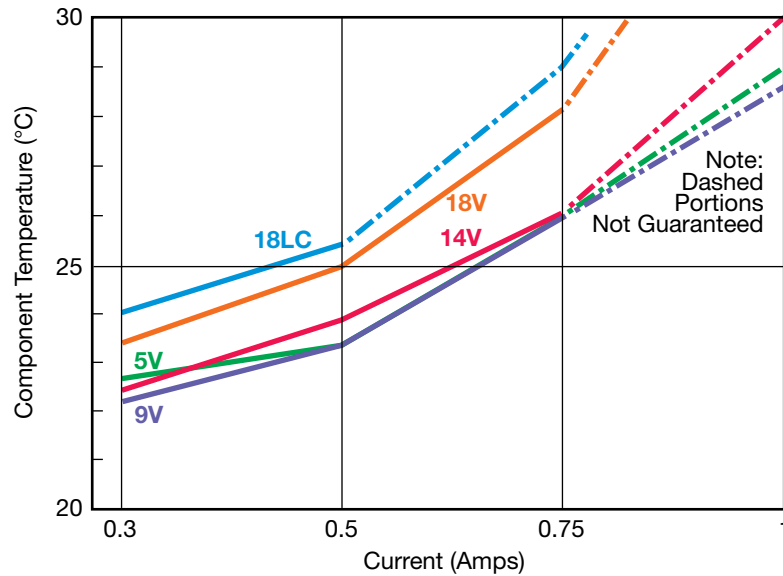

CURRENT vs TEMPERATURE

0805 – 0.3 Joule

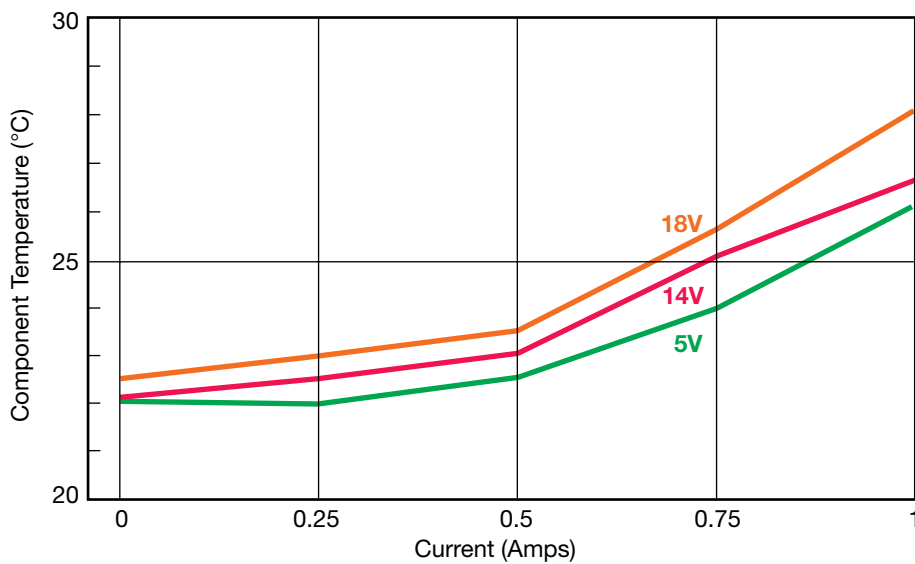

PERFORMANCE CHARACTERISTICS

FEEDTHRU VARISTORS

AVX Multilayer Feedthru Varistors (MLVF) are an ideal choice for system designers with transient strike and broadband EMI/RFI concerns.

Feedthru Varistors utilize a ZnO varistor material and the electrode pattern of a feedthru capacitor. This combination allows the package advantage of the feedthru and material advantages of the ZnO dielectric to be optimized.

ZnO MLV Feedthrus exhibit electrical and physical advantages over standard ZnO MLVs. Among them are:

1. Faster Turn on Time
2. Broadband EMI attenuation
3. Small size (relative to discrete MLV and EMI filter schemes)

The electrical model for a ZnO MLV and a ZnO Feedthru MLV are shown below. The key difference in the model for the Feedthru is a transformation in parallel to series inductance. The added series inductance helps lower the injected transient peak current (by $2\pi fL$) resulting in an additional benefit of a lower clamping voltage. The lowered parallel inductance decreases the turn on time for the varistor to <250ps.

Discrete MLV Model

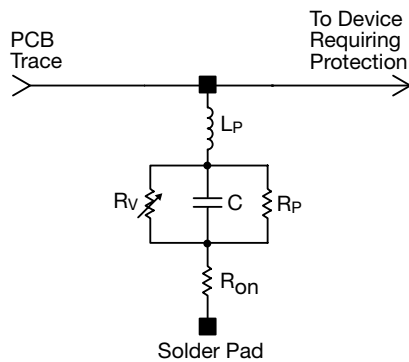

Where: R_v = Voltage Variable resistance (per VI curve)
 $R_p \geq 10^{12} \Omega$
 C = defined by voltage rating and energy level
 R_{on} = turn on resistance
 L_p = parallel body inductance

Discrete MLVF Model

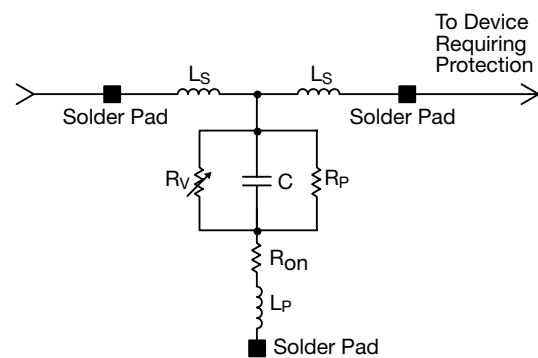

Where: R_v = Voltage Variable resistance (per VI curve)
 R_p = Body IR
 C = defined by voltage rating and energy level
 R_{on} = turn on resistance
 L_p = minimized parallel body inductance
 L_s = series body inductance

TransFeed

AVX Multilayer Ceramic Transient Voltage Suppressors TVS Protection and EMI Attenuation in a Single Chip



PERFORMANCE CHARACTERISTICS

APPLICATIONS

- EMI Suppression
- Broadband I/O Filtering
- Vcc Line Conditioning

FEATURES

- Small Size
- Low ESR
- Ultra-fast Response Time
- Broad S21 Characteristics

MARKET SEGMENTS

- Computers
- Automotive
- Power Supplies
- Multimedia Add-On Cards
- Bar Code Scanners
- Remote Terminals
- Medical Instrumentation
- Test Equipment
- Transceivers
- Cellular Phones / Pagers

TYPICAL CIRCUITS REQUIRING TRANSIENT VOLTAGE PROTECTION AND EMI FILTERING

The following applications and schematic diagrams show where TransFeed TVS/ EMI filtering devices might be used:

- System Board Level Interfaces: (Fig. 1)
Digital to RF
Analog to Digital
Digital to Analog
- Voltage Regulation (Fig. 2)
- Power Conversion Circuits (Fig. 3)
- GaAs FET Protection (Fig. 4)

Fig. 1 – System Interface

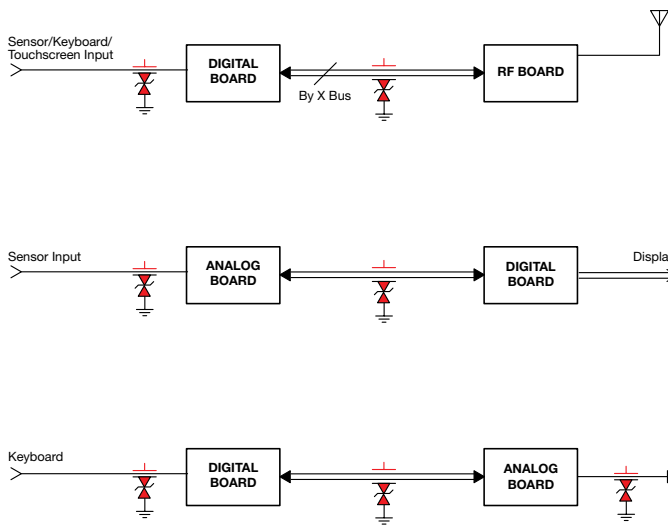

Fig. 2 – Voltage Regulators

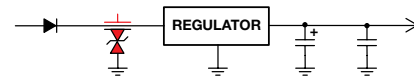

Fig. 3 – Power Conversion Circuits/Power Switching Circuits

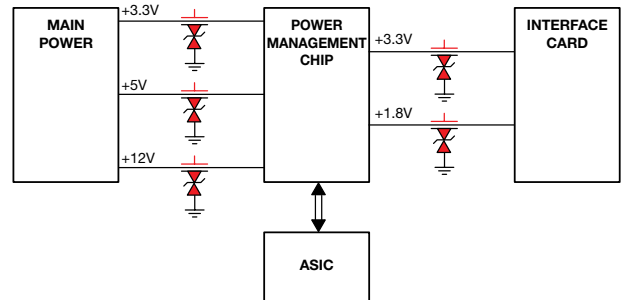
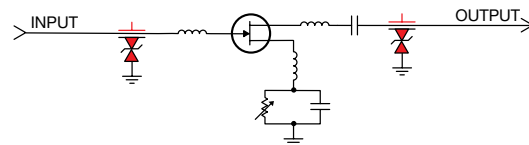

Fig. 4 – GaAs FET Protection



SPECIFICATION COMPARISON

MLVF 0805	PARAMETER	MLV 0805
5ph	L_s typical	N/A
<600nh	L_p typical	<1.5nh
<0.025 Ω	R_{on} typical	<0.1 Ω
100pf to 2.5nf	C typical	100pf to 5.5nf
see VI curves	R_v typical	see VI curves
>0.25 x 10 ¹² Ω	R_p typical	>1 x 10 ¹² Ω
<250ps	Typical turn on time Typical frequency response	<500ps

A comparison table showing typical element parameters and resulting performance features for MLV and MLVF is shown above.

ASIC RESET & V_{CC} PROTECTION

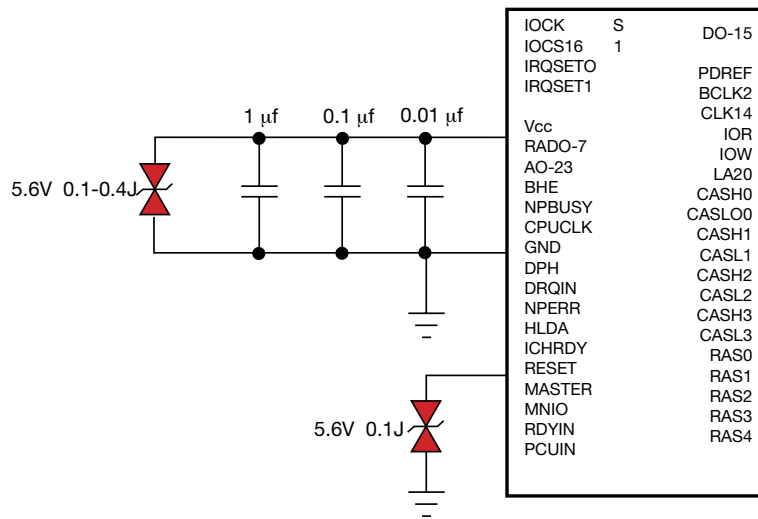

MICRO CONTROLLERS RELAYS, DC MOTORS

TRANSGUARD CHARACTERISTICS

WORKING VOLTAGE ≥ RELAY OR MOTOR VOLTAGE
 ENERGY RATING TYPICALLY > 0.3J
 CAPACITANCE IS OF NO CONCERN

CMOS RELAY DRIVER

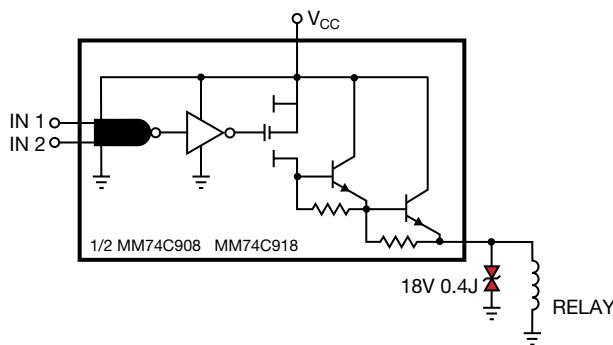

LM319 RELAY DRIVER

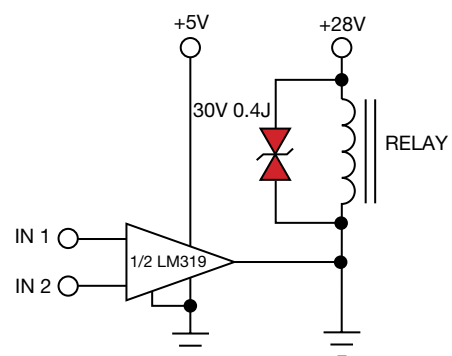

= TransGuard

I/O PORT PROTECTION

TRANSGUARD CHARACTERISTICS

WORKING VOLTAGE TYPICALLY 14V - 18V
 ENERGY RATING TYPICALLY 0.05J - 0.1J
 CAPACITANCE SHOULD BE MINIMIZED

SUB NOTEBOOK & PDA'S

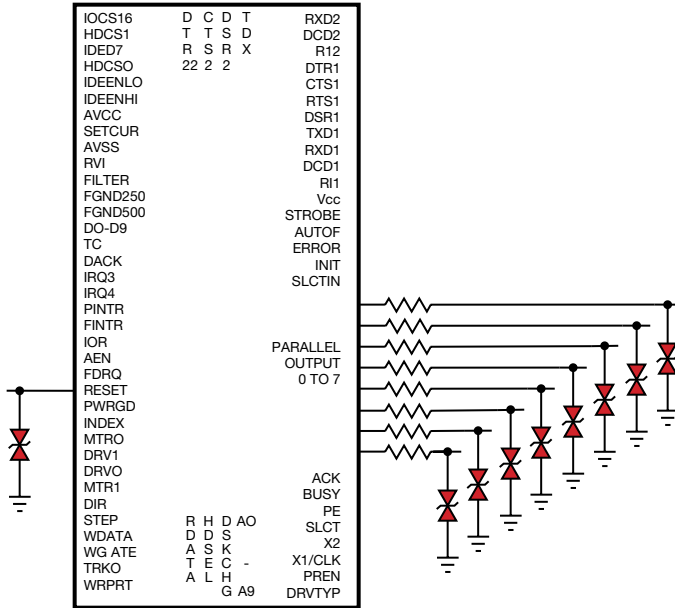

NOTEBOOK & WORK STATION

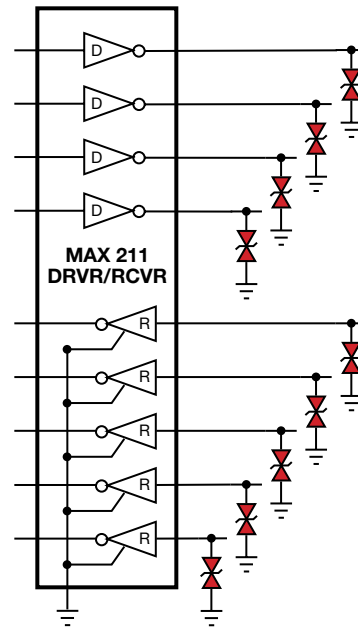

KEYBOARD PROTECTION

TRANSGUARD CHARACTERISTICS

WORKING VOLTAGE >5.6V
 ENERGY RATING TYPICALLY <0.4J
 CAPACITANCE PREFERRED TO BE MINIMUM

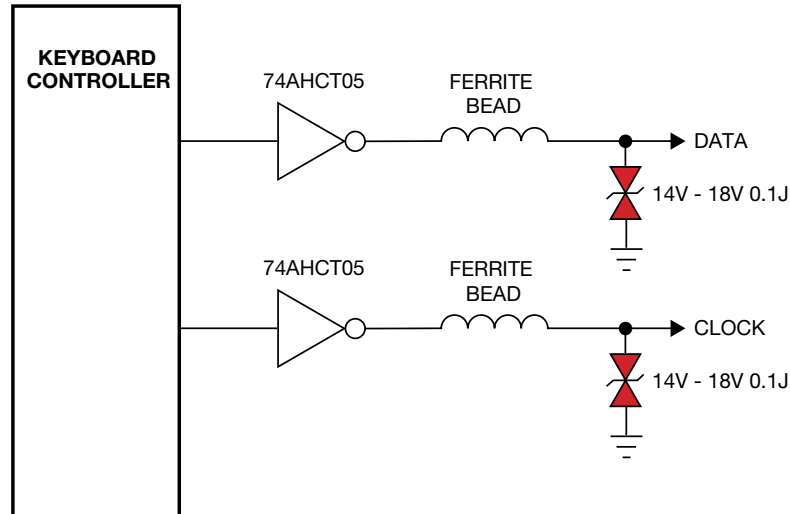

= TransGuard

MODEM PROTECTION

TRANSGUARD CHARACTERISTICS

WORKING VOLTAGE <26V
ENERGY RATING ≥ 0.1J

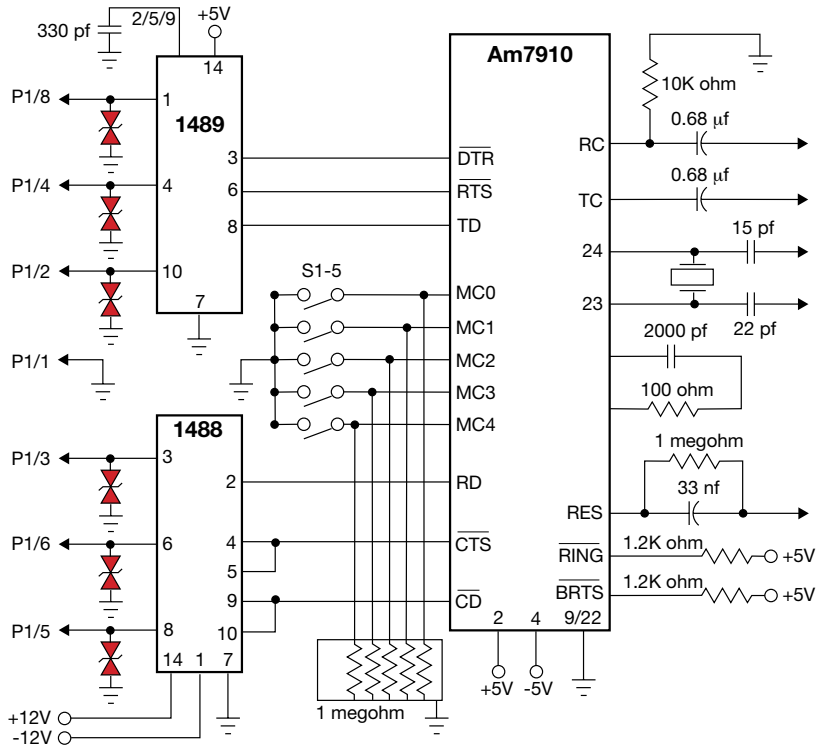

SENSOR PROTECTION

TRANSGUARD CHARACTERISTICS

WORKING VOLTAGE TYPICALLY >14V
ENERGY RATING > 0.4J
CAPACITANCE IS NO CONCERN

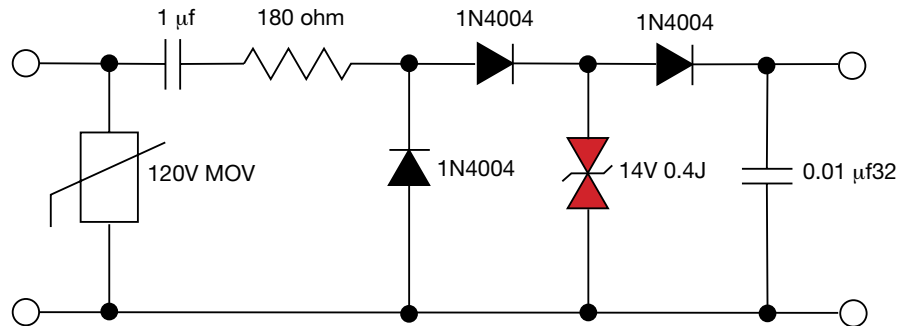

= TransGuard

ANTENNA AND PREAMPLIFIER PROTECTION

TRANSGUARD CHARACTERISTICS

WORKING VOLTAGE TYPICALLY 18V - 26V
 ENERGY RATING 0.05J - 0.9J
 CAPACITANCE OF CONCERN ON MANY DESIGNS

PREAMPLIFIER PROTECTION

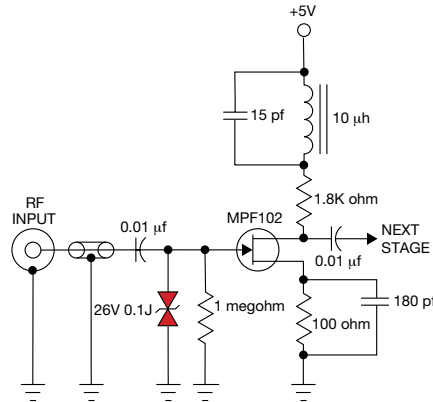

AUDIO CIRCUIT PROTECTION

TRANSGUARD CHARACTERISTICS

WORKING VOLTAGE TYPICALLY 14V - 18V
 ENERGY RATING 0.1J

PAGER AUDIO PROTECTION

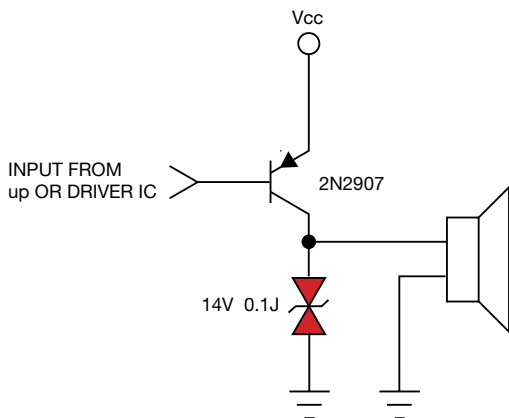

NOTEBOOK, WORK STATION AUDIO PROTECTION

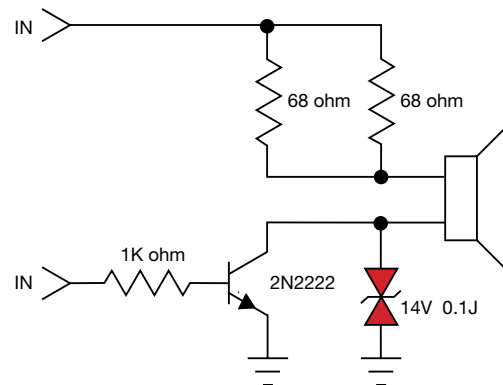

= TransGuard

LCD PROTECTION

TRANSGUARD CHARACTERISTICS

WORKING VOLTAGE < 5.6V
ENERGY RATING < 0.1J

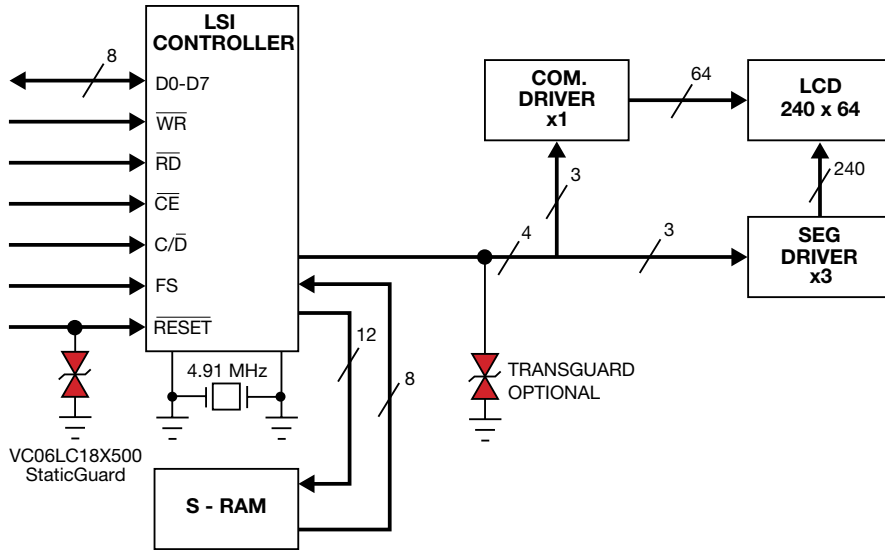

OPTICS PROTECTION

TRANSGUARD CHARACTERISTICS

WORKING VOLTAGE $\leq 18V$
ENERGY RATING 0.1J
CAPACITANCE SHOULD BE MINIMIZED

OPTO ISOLATER PROTECTION

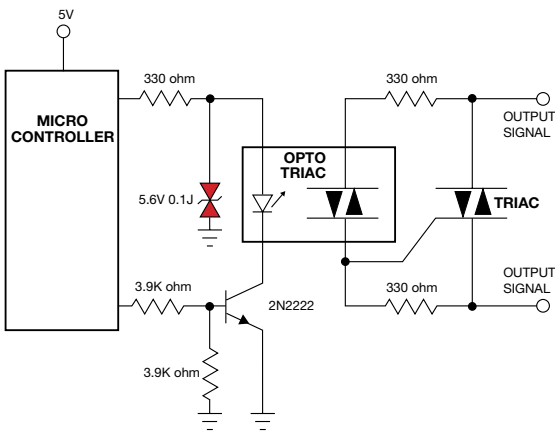

LASER DIODE PROTECTION

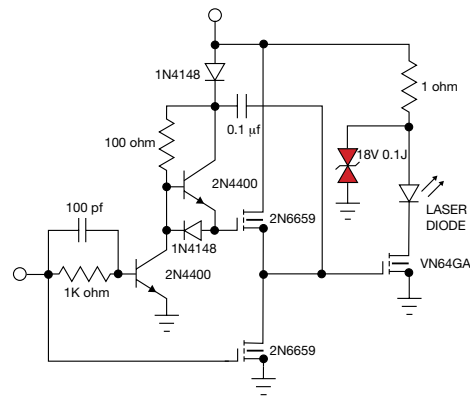

= TransGuard

AVXTransGuard[®]

APPLICATION NOTES

- AVX Multilayer Varistors – Assembly Guidelines
- IEC 61000-4 Requirements
- Turn On Time Characteristics of AVX Multilayer Varistors
- The Impact of ESD on Insulated Portable Equipment
- AVX TransGuard Motor and Relay Application Study
- AVX Multilayer Varistors in Automobile MUX Bus Applications

AVX Multilayer Varistors – Application Notes

TRANSGUARD SURFACE MOUNT DEVICES

The move toward SMT assembly of Transient Voltage Suppressors (TVS) will continue accelerating due to improved long-term reliability, more efficient transient voltage attenuation and size/functionality/cost issues.

TransGuards are uniquely suited for wide-scale usage in SMT applications. TransGuards exhibit many advantages when used in SMT assemblies. Among them are:

- Available in standard EIA chip sizes 0402/0603/0805/1206/1210.
- Placed with standard equipment (8mm tape and reel).
- Processed with fewer guidelines than either ceramic chip or resistor chip devices.
- Exhibit the highest energy/volume ratio of any EIA size TVS.

This general guideline is aimed at familiarizing users with the characteristics of soldering multilayer SMT ZnO TransGuards. TransGuards can be processed on wave or infrared reflow assembly lines. For optimum performance, EIA standard solder pads (land areas) shown in Figure 1 are recommended regardless of the specific attachment method.

Dimensions: mm (inches)

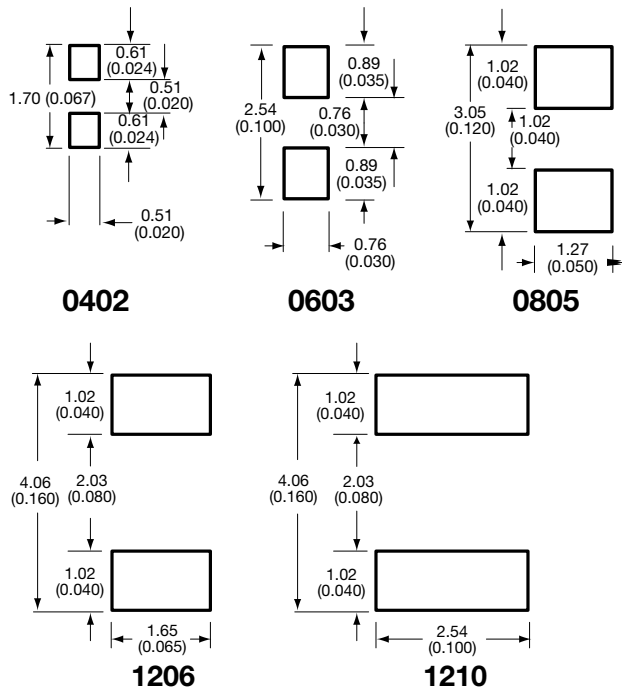

Figure 1: TransGuard Solder Pad Dimensions

STORAGE

Good solderability of plated components is maintained for at least twelve months, provided the components are stored in their “as received” packaging at less than 30°C and 85% RH.

SOLDERABILITY

Plated terminations will be well soldered after immersion in a 60/40 tin/lead solder bath at 235°C ±5°C for 5 ±1 seconds.

LEACHING

Plated terminations will resist leaching for at least 30 seconds when immersed in 60/40 tin/lead solder at 260°C ±5°C.

RECOMMENDED SOLDERING PROFILES

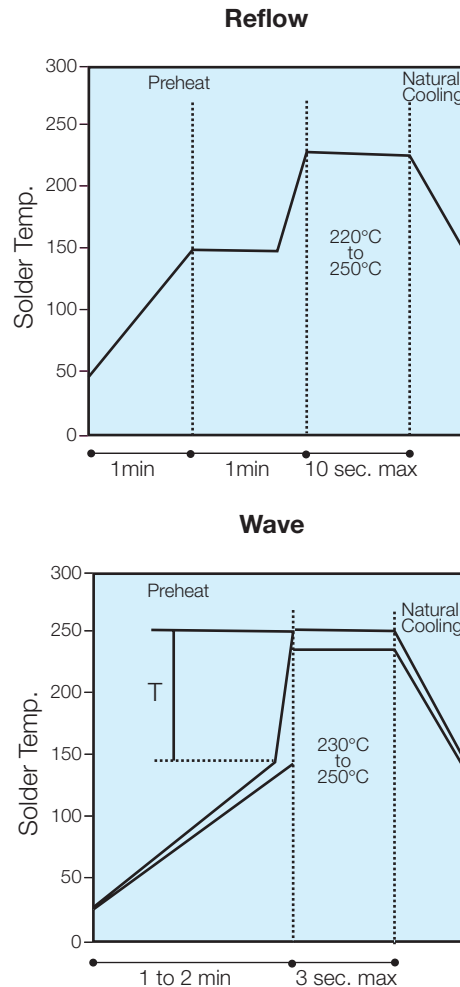

GENERAL

Surface mount multilayer varistors (MLVs) are designed for soldering to printed circuit boards or other substrates. The construction of the components is such that they will withstand the time/temperature profiles used in both wave and reflow soldering methods.

HANDLING

MLVs should be handled with care to avoid damage or contamination from perspiration and skin oils. The use of tweezers or vacuum pickups is strongly recommended for individual components. Bulk handling should ensure that abrasion and mechanical shock are minimized. Taped and reeled components provide the ideal medium for direct presentation to the placement machine.

PREHEAT

It is important to avoid the possibility of thermal shock during soldering and carefully controlled preheat is therefore required. The rate of preheat should not exceed 4°C/second and a target figure 2°C/second is recommended.

SOLDERING

Mildly activated rosin fluxes are preferred. The minimum amount of solder to give a good joint should be used. Excessive solder can lead to damage from the stresses caused by the difference in coefficients of expansion between solder, chip and substrate. AVX terminations are suitable for all wave and reflow soldering systems. If hand soldering cannot be avoided, the preferred technique is the utilization of hot air soldering tools.

COOLING

Natural cooling in air is preferred, as this minimizes stresses within the soldered joint. When forced air cooling is used, cooling rate should not exceed 4°C/second.

CLEANING

Flux residues may be hygroscopic or acidic and must be removed. AVX MLVs are acceptable for use with all of the solvents described in the specifications MIL-STD-202 and EIA-RS-198. Alcohol-based solvents are acceptable and properly controlled water cleaning systems are also acceptable. Many other solvents have been proven successful, and most solvents that are acceptable to other components on circuit assemblies are equally acceptable for use with MLVs.

POST SOLDER HANDLING

Once the components are soldered to the board, any bending or flexure of the PCB applies stresses to the soldered joints of the components. For leaded devices, the stresses are absorbed by the compliancy of the metal leads and generally don't result in problems unless the stress is large enough to fracture the soldered connection.

Surface mount devices are more susceptible to such stress because they don't have compliant leads and are brittle in nature. The most frequent failure mode is high leakage current (or low breakdown voltage). Also, a significant loss of capacitance due to severing of contact between sets of internal electrodes may be observed.

Cracks caused by mechanical flexure are very easily identified and generally take one of the following two general forms:

Type A:

Angled crack between bottom of device to top of solder joint.

Type B:

Fracture from top of device to bottom of device.

Mechanical cracks are often hidden underneath the termination and are difficult to see externally. However, if one end termination falls off during the removal process from PCB, this is one indication that the cause of failure was excessive mechanical stress due to board flexure.

COMMON CRACKS OF MECHANICAL CRACKING

The most common source for mechanical stress is board depanelization equipment, such as manual breakapart, v-cutters and shear presses. Improperly aligned or dull cutters may cause torquing of the PCB resulting in flex stresses being transmitted to components near the board edge. Another common source of flexural stress is contact during parametric testing wncB,e due to severing of contact between sets of

AVX Multilayer Varistors – Application Notes

REWORKING ASSEMBLIES

Thermal shock is common in MLVs that are manually attached or reworked with a soldering iron. *AVX strongly recommends that any reworking of MLVs be done with hot air reflow rather than soldering irons.*

Direct contact by the soldering iron tip often causes thermal cracks that may fail at a later date. If rework by soldering iron is absolutely necessary, it is recommended that the wattage of the iron be less than 30 watts and the tip temperature be <300°C. *Rework should be performed by applying the solder iron tip to the pad and not directly contacting any part of the component.*

VARISTOR SOLDERABILITY

Historically, the solderability of Multilayer Varistors (MLVs) has been a problem for the electronics manufacturer. He was faced with a device that either did not wet as well as other electronic components, or had its termination material leached away during the assembly process. However, by utilizing proprietary procedures, AVX Corporation provides the market with a MLV that has solderability comparable to that of other electronic components, and resists leaching during assembly.

BACKGROUND

The basic construction of an unplated MLV is presented in Figure 1. The external termination is a metal that connects

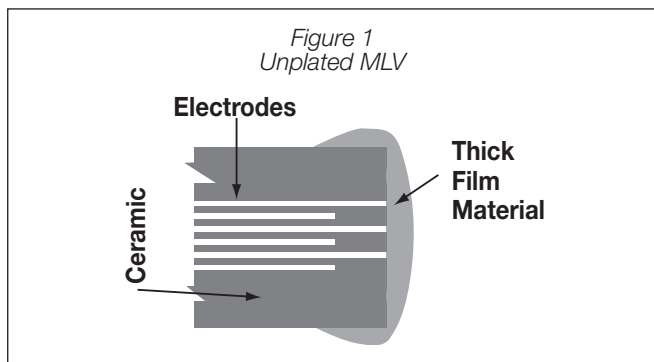

the internal electrodes to the circuitry of the assembly using the MLV. The external electrode must accomplish two goals. First, it must be sufficiently solderable to allow the solder used in assembly to wet the end of the chip and make a reliable connection to the traces on the circuit board. Second, it must be robust enough to withstand the assembly process. This is particularly important if wave soldering is used. Unfortunately these two goals are competing. In order to achieve good solderability, an alloy high in silver content is chosen. However, this alloy is prone to leaching during assembly, so an additional metal is added to improve the leach resistance. While this improves the leach resistance, this addition makes the termination less solderable. The results are either terminations that leach away, or do not solder well (see the photographs in Figure 2).

Clearly, a plated termination system (as seen in Figure 3) is desired. This system, which is typical of other electronic components such as capacitors and resistors, produces a much better assembled product.

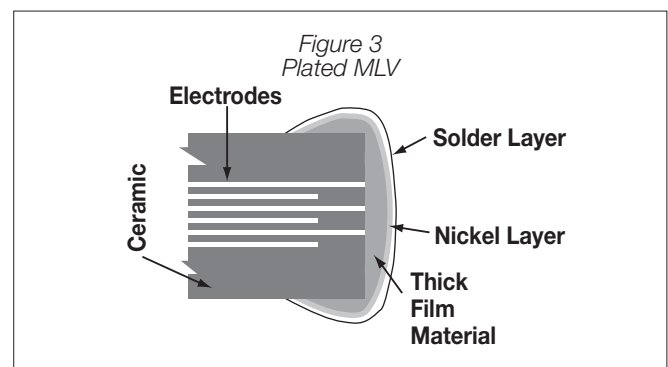
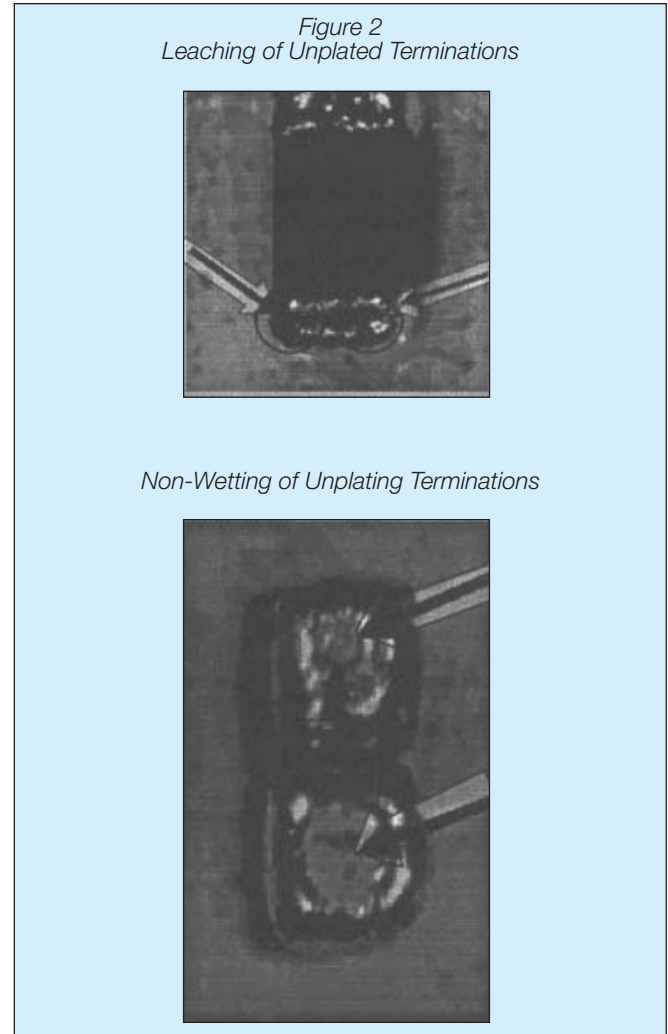

In the plated termination, the base termination layer is still used (it provides contact from the electrodes to the circuitry). On top of the base termination is a layer of nickel. This is the surface to which the solder bonds during assembly. It must be thick enough to stay intact during IR reflow or wave

AVX Multilayer Varistors – Application Notes

soldering so that the thick film material does not leach away. It must also be thick enough to prevent the inter-metallic layer between the thick film termination and the nickel layer from affecting the solderability.

In order to protect the nickel (i.e., maintain its solderability), a layer of solder is plated on top of the nickel. The solder preserves the solderability of the nickel layer. It must be thick and dense to keep oxygen and water from reaching the nickel layer.

THE CHALLENGE

Zinc oxide varistors are semi-conductive in nature – that is what allows them to “turn on” and divert a damaging transient away from sensitive electronic circuitry and safely to ground. This semi-conduction poses a major problem for the manufacturer that wants to plate the terminations – the ceramic plates also! This condition, overplating, must be controlled, as it is cosmetically undesirable and could result in an unwanted path of conduction across the chip.

Early efforts in plating MLVs revolved around limiting the time that the chip was in the plating bath. This helped prevent overplating, but also produced chips with marginal solderability. The photographs in Figure 4 depict the problems that occur when the plated layers are not thick enough.

THE SOLUTION

AVX has developed a proprietary process that passivates the ceramic surface of the MLV. This allows us to plate the parts for a longer time without getting the overplate. This results in significantly thicker layers of nickel and alloy plated onto the base termination. These thicker layers translate into bond strengths that are typically twice those of our competitors and solder fillets and parts that pass all measured of solderability (as seen in Figure 5).

AVX: The solution for MLV assembly problems.

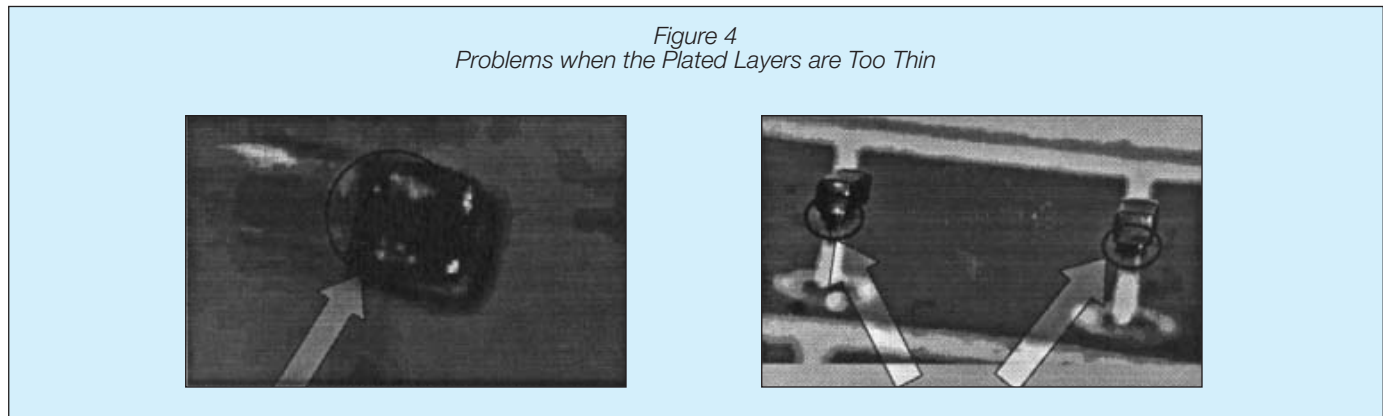

WHAT IS IEC 61000-4?

The International Electrotechnical Commission (IEC) has written a series of specifications, IEC 61000-4, which mandate the performance of all electronic devices in a variety of transient and incident RF conditions. This specification requirement resulted as part of Europe's move toward a single market structure and a desire to formalize and harmonize current member countries' requirements. As of January 1, 1996, all electronic and electrical items sold to Europe must meet IEC 61000-4 series specifications.

WHY IS IEC 61000-4 REQUIRED BY EUROPE?

The various regulatory agencies within Europe feel that the IEC 61000-4 series of specifications is necessary to insure acceptable performance of electronic equipment in a world filled with increasingly more Electromagnetic Interference - EMI. Furthermore, as electronic systems become more portable, and the transient susceptibility of semiconductors increases, government regulations are essential to maintain a minimum level of performance in all equipment. Europe is so serious about the problem that they require that equipment be certified via testing to meet IEC 61000-4 series specifications after 1/1/96 to avoid fines and prosecution.

HOW DO COMPANIES SELLING ELECTRONIC SYSTEMS MEET IEC 61000-4 PARTS 2-5 SPECIFICATIONS?

Companies and design engineers must now use protective circuits or devices to meet these requirements. First, a description of IEC 61000-4/2-6 is in order:

IEC 61000-4-2 ESD TESTING REQUIREMENTS

All equipment destined for Europe must be able to withstand 10 strikes of ESD waveforms with $T_r < 1\text{ns}$ in contact discharge mode (preferred) at pre-selected points accessible during normal usage or maintenance. Testing shall be performed at one or more of four (4) severity levels, depending upon equipment category.

Level	Contact Discharge ¹ Mode Test Voltage kV	Air Discharge Mode Test Voltage kV
1	2	2
2	4	4
3	6	8
4	8	15

61000-4-2 Test Conditions

¹Preferred mode of testing due to repeatability.

WAVEFORM PARAMETERS

Level	Test Voltage Level kV	First Peak of Discharge Current Amps $\pm 10\%$	TR nS	30 nS Current Amps $\pm 30\%$	60 nS Current Amps $\pm 30\%$
1	2	7.5	0.7 -1	4	2
2	4	15	0.7 -1	8	4
3	6	22.5	0.7 -1	12	6
4	8	30	0.7 -1	16	8

Upon completion of the test, the system must not experience upset (data or processing errors) or permanent damage. The waveforms are to be injected at or along the DUT's body which is accessible in normal set-up and operation.

IEC 61000-4-3 ELECTROMAGNETIC COMPATIBILITY IMPACT TESTING (EMC)

This test is concerned with the susceptibility of equipment when subjected to radio frequencies of 27 MHz to 500 MHz. The system must be able to withstand three (3) incident radiation levels:

- Level 1** 1V/m field strength
- Level 2** 3V/m field strength
- Level 3** 10V/m field strength
- Level X** User defined > 10V/m field strength

The system must not experience upset (data or processing errors) or permanent errors.

IEC 61000-4-4 ELECTRICAL FAST TRANSIENT (EFT) TESTING

The EFT test is modeled to simulate interference from inductive loads, relay contacts and switching sources. It consists of coupling EFT signals on I/O parts, keyboard cables, communication lines and power source lines. The system, depending upon appropriate severity level, must be able to withstand repetition rates of 2.5 kHz to 5 kHz for ≥ 1 minute as follows:

	Open Circuit Output Voltage/10%	
On Power Supply	On I/O, Signal, Data, Control lines	
Level 1	0.5kV	0.25kV
Level 2	1kV	0.5kV
Level 3	2kV	1kV
Level 4	4kV	2kV

IEC 61000-4-5 UNIDIRECTIONAL POWER LINE SURGE TEST

The details of this specification for high energy disturbances are being addressed in several drafts under discussion within the EC at this time.

IEC 61000-4-6 CONDUCTED RF TEST FROM 9kHz TO 80MHz

The details of this specification for conducted broad band RF signals are being addressed in a first edition draft within the EC at this time.

Designers have the option of using AVX TransGuards to meet IEC 61000-4-2, 3 and 4.

In the case of IEC 61000-4-2 TransGuards can be used to suppress the incoming Transient just like a Zener diode would. TransGuards, however, exhibit bipolar characteristics, a faster turn-on-time (<1nS), a better repetitive strike capability and superior thermal stability to the Zener suppression device. Furthermore, TransGuards are typically smaller and lighter when placed on SMT circuit boards. See Figure 1 for data illustrating IEC 61000-4-2 repetitive strike capability.

The TransGuards effective capacitance allows the device to be used to meet IEC 61000-4-3 and 61000-4-4. The device's parallel capacitance can be used as effectively as a capacitor to block low level incident and conducted RF energy. If in the case of some levels of IEC 61000-4-3 and IEC 61000-4-4 when the intensity of pulse is greater than the device's breakdown capability it will then turn on and suppress via MOV means rather than capacitance (as in the small signal case). Effectiveness hinges upon the proper placement of the device within the PCB (which is usually easily accomplished since TransGuards are so small).

SUMMARY

AVX TransGuards are exceptionally suited to meet the defined portions of the IEC 61000-4 document. Experimentation is critical to proper choice and selection of devices to suppress 61000-4-3/4. Samples are available from your local sales representative.

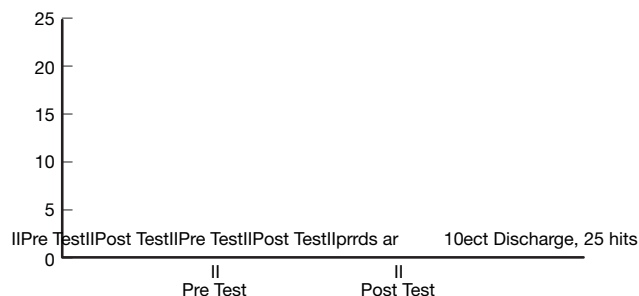

25kV Direct Discharge, 25 hits)T /Docum0 k.2 /T1 1 1.8.40355.346.174.2118Tw 5 049Td 8

INTRODUCTION

Due to the growing importance of ESD immunity testing, as required by the EMC Directive, proper selection of voltage suppressor devices is critical. The proper selection is a function of the performance of the device under transient conditions. An ideal transient voltage suppressor would reach its “clamping voltage” in zero time. Under the conditions imposed by the 1991 version of IEC 61000-4-2, the actual turn-on-time must be less than one nanosecond to properly respond to the fast leading edge of the waveform defined in the standard.

It has been found during testing of transient suppressors that the response time is very closely dictated by the packaging of the device. Inductance that is present in the connection between the silicon die and the leads of the device creates an impedance in series with the suppressor device; this impedance increases the overall device response time, reducing the effectiveness of the suppressor device.

The purpose of this paper is to present the Turn on Time characteristics of Multilayer Varistors (MLVs) and to compare the MLV Turn on Time to that of various silicon transient voltage suppressors (SiTVs).

The Turn on Time of a transient voltage suppressor (TVS) is of growing importance since IEC 61000-4-2 now specifies ESD waveform with a rise time < 1 ns. Therefore, TVS’s must have a turn on time < 1 ns to effectively suppress ESD. In many, if not all, ESD suppression applications, TVS turn on time can be of more importance than absolute clamping voltage (V_c) of the TVS (assuming that the TVS clamping voltage is less than the damage voltage of the circuit or IC).

To measure the turn on time of today’s TVS’s, a broad cross section of MLVs and SiTVs were chosen. Only surface mount devices were chosen in order to best represent today’s TVS current usage/trends and to keep the test matrix to a reasonable level of simplicity. The following devices were tested:

SMT MLV	SiTVS
	MA141WA
0603	BAV 99
0805	SOT 23 type
1206	SMB - 500W gull-wing SM device
1210	SMC - 1500W gull-wing SM device

TEST PROCEDURE

The TVS device under test (DUT) was placed on a PCB test fixture using SN60/40 solder. The test fixture (see Figure 1) was designed to provide an input region for an 8kV contact ESD discharge waveform (per IEC 61000-4-2 level 4 requirements). In addition, the fixture was designed to provide low impedance connections to the DUTs.

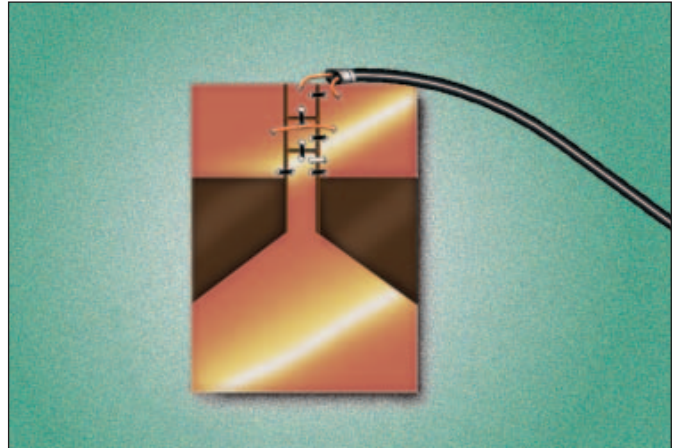

Figure 1. DUT Test Fixture

The ESD pulse was injected to the PCB from a Keytek mini-zap ESD simulator. Additionally, the fixture was to channel the ESD event to a storage oscilloscope to monitor the suppressor’s response. Six resistors were used on the PCB to provide waveshaping and an attenuated voltage to the storage scope (see Figure 2):

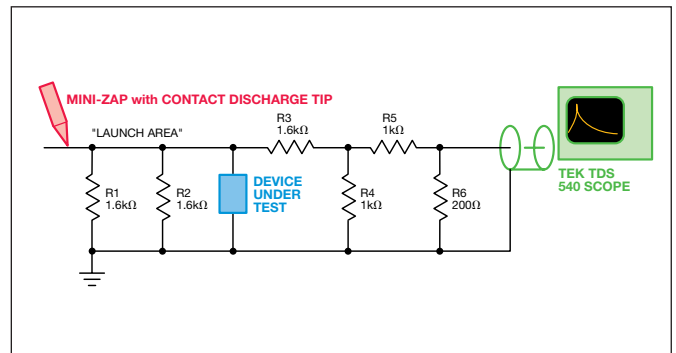

Figure 2. Schematic of Test Set Up

AVX Multilayer Ceramic Transient Voltage Suppressors Application Notes: Turn on Time Characteristics of AVX Multilayer Varistors

The functions of the resistors are as follows: The resistor values were adjusted in “open circuit” conditions to obtain best open circuit response.

R1, R2 (1.6K) - provide wave shaping during the ESD discharge event

R3 (1.6K), R4 (1K), R5 (1K) - Form a 60 dB Attenuator (1000:1 ratio) for input of Tektronix TDS 540 1 giga sample/second storage oscilloscope

R6 (200 Ω) - provides matching to the 50 ohm coax feeding the TDS 540 oscilloscope.

The open circuit response of the ESD test fixture with a 9kV ESD pulse is shown in Figure 3.

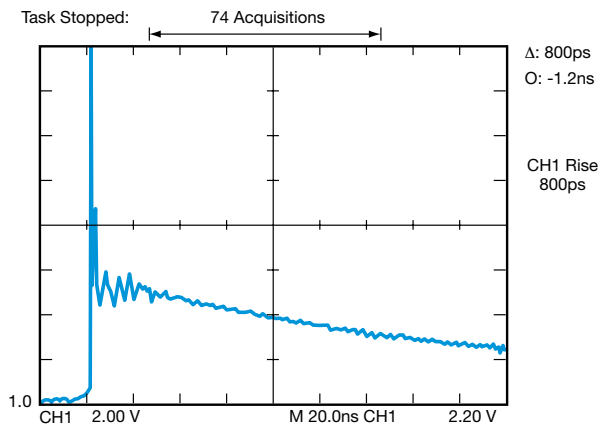

Figure 3. Open Circuit Response of Test Fixture to an Injected ESD Waveform

The graph shows the voltage attenuated by a factor of 1000, with a 800ps risetime for the ESD waveform (this agrees with typical data given by Keytek for equipment performance). It should be noted that only the positive polarity was tested. Prior testing showed turn on time was not dependent upon waveform polarity (assuming that DUTs are bidirectional).

TEST RESULTS

MLV TURN ON TIME TRANSGUARDS

The turn on time test results for AVX TransGuards showed that all case sizes were capable of a sub-nanosecond turn on response. This corresponds favorably with the calculated turn on time of less than 1 ns. Specific performance data follows:

AVX TransGuard	
CASE SIZE	TURN ON SPEED
0603	< 0.7 ns
0805	< 0.9 ns
1206	< 0.9 ns
1210	< 0.8 ns

TVS TURN ON TIME

Test results for SiTVs varied widely depending upon the physical size and silicon die mounting configuration of the device. The results agree with several SiTVs manufacturers papers indicating that the absolute response from the silicon die could be < 1 ns. However, when the die is placed in a package, the turn on time delay increases dramatically. The reason for this is the series inductance of the SiTVs packaging decreases the effective response time of the device. Reports of 1-5 ns are frequently referred to in SiTVs manufacturers publications. Further, the turn on times for SiTVs vary dramatically from manufacturer to manufacturer and also vary within a particular manufacturers lot. The data provided in the following table generally agreed with these findings:

SiTVS	
CASE SIZE	TURN ON SPEED
MA141WA	0.8ns
BAV 99	0.9ns to 1.2ns
SOT 23 Type	0.8ns
SMB	1.5ns to 2.2ns
SMC	1.5ns to 3ns

SUMMARY

This test confirms calculations that show that AVX TransGuards have a true sub-nanosecond turn on time. Although the silicon die of a SiTVs has a sub-nanosecond response, the packaged SiTVs typically has a response time much slower than a TransGuard. If the two devices were directly compared on a single graph (see Figure 4), it could be shown that the TransGuard diverts significantly more power than even the fastest SiTVs devices. Additionally, TransGuards have a multiple strike capability, high peak inrush current, high thermal stability and an EMI/RFI suppression capability which diodes do not have.

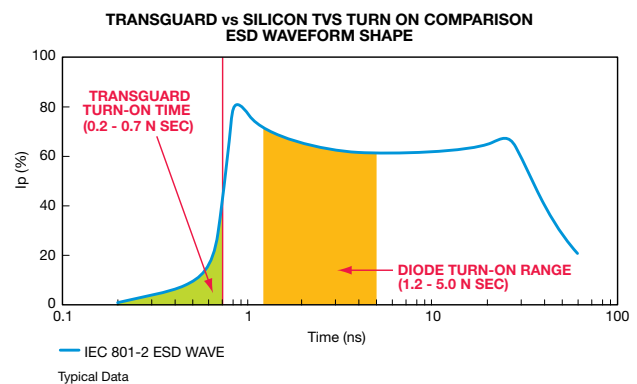

Figure 4.

The purpose of this discussion is to recap the impact ESD has on portable, battery powered equipment. It will be shown that ESD can cause failures in “floating ground systems” in a variety of ways. Specifically, ESD induced failures can be caused by one or more of its complex components:

- Predischarge* - Corona Generated RF
- Predischarge* - E Field
- Discharge* - Collapsing E Field
- Discharge* - Collapsing H Field
- Discharge* - Current Injection...Voltage...Additional Fields

With this in mind it will be shown that the only way to insure equipment survivability to ESD is to use a Transient Voltage Suppressor (in addition to proper circuit layout, decoupling, and shielding).

In order to get a better understanding of what happens in an ESD event the charge developed by a human body should be defined. The ESD schematic equivalent of the human body model is shown in Figure 1. Typically, the charge developed on a person can be represented by a 150pF capacitor in series with a resistance of 330 ohms. The energy of an ESD waveform generated from this model is $Q = 1/2 CV^2$ where Q = total energy in Joules, C = capacitance of the human body model in farads and V = charging voltage in volts.

Voltages can be as high as 25 kV, however typical voltages seen are in the 8 to 15 kV regions.

In the predischarge scenario (Figure 2) a human charged to -20 kV may approach a battery powered “system” on a table. As the person reaches toward the system electrostatics dictate that the system will have an equal and opposite charge on the system’s surface nearest to the person. Since the system we are approaching is isolated from ground, the charge is only redistributed among the device. (If the system were grounded a current would be generated by the loss of electrons to ground. The system would then become positive relative to ground). The rate of approach of the human body model affects the charging current to a small extent. However, most importantly, it is the electrostatic field and the unequal voltages which developed across the equipment that cause the destruction of components within the system. In general, unprotected IC’s (particularly CMOS) are susceptible to damage due to induced E field voltages. This problem is further complicated by the device type and complexity and the fact that the breakdown voltage of a generic IC will vary greatly from manufacturer to manufacturer (Figure 3). This brief discussion should be adequately convincing that electrostatically induced E field can impact system reliability. IC protection can be achieved by placing a transient suppressor on the most susceptible pins of the sensitive IC’s (e.g., Vcc and I/O pins, etc.).

PREDISCHARGE E FIELD FAILURES

Now that we have a definition of the basic ESD human body model we can discuss the predischarge E field failure mode.

CONTACT DISCHARGE FAILURES

As the charged person gets closer to the system, the situation is more complex. First a much more detailed human body model is needed to represent the complex transmission line which will transport energy to the system (see Figure 4). In this discussion we will only consider the case of a single contact discharge. In the real world, however, multiple discharges will likely occur (possibly caused by a person’s hand reacting to an ESD spark and then touching the system again, etc.).

In contact discharge, when a charged person approaches the system, E fields are induced. As the person gets closer to the system, the field intensity becomes greater, eventually reaching a point large enough to draw an arc between the



TransGuard[®]

AVX Multilayer Ceramic Transient Voltage Suppressors

Application Notes: Motor and Relay Application Study



PURPOSE

A significant number of end customers have experienced failures of circuitry in and around low voltage relays and motors. Additionally, EMI problems have been associated with running motors.

This study is aimed at evaluating how TransGuards can reduce EMI from running motors and clamp transients generated from relays and motors during power off.

DESCRIPTION

Three different motors and two different relays were chosen to represent the wide range of possible devices used by designers. Device choices were as follows:

MOTORS

Cramer 8001 series Geared Motor
12V, 30rpm (4800 RPM armature speed) 170ma
Start/Run Torque 30oz

Comair Rotron DC Biscuit Fan - 24V, 480ma

Comair Rotron DC Biscuit Fan - 12V, 900ma

RELAYS

Potter and Brumfield 24V Relay
1/3 HP 120V AC, 10A 240 VAC Rating

Potter and Brumfield 12V Relay
1/3 HP 120V AC, 10A 240 VAC Rating

A Tektronix TDS 784A four channel 1GHz 4G S/s digitizing storage scope was used to capture the -1/2 LI2 transient peak from the relays and motors. A x10 probe was

connected to the scope and one leg of the relay/motor coil; the probe's ground was connected to the other relay coil/motor wire. The scope was triggered on the pulse and waveforms printed.

When suppression was introduced into the circuit, it was placed directly on the relay coils/motor lead wires. The axial TransGuard and capacitors had a 19mm (3/4") total lead length in each case. Upon careful consideration, it was determined that this was a fairly common lead length for such applications.

SUMMARY

GEARED MOTOR

The Cramer geared motor was tested while running (under load) to determine its "on state" noise as well as under loaded turn off conditions. Both TransGuards and ceramic capacitors were tested to determine the level of protection they offer.

A 14V axial TransGuard provided the best protection during running and turn off. The VA100014D300 TransGuard cut the 60V unprotected turn off voltage spike to 30V. It also cut the on state noise to 4.0V pk-pk due to its internal capacitance. The following is a summary of measured voltages (scope traces are shown in Figures 1, 1A, 2, 2A).

Test Condition	Transient without Protection	Transient with .1µF cap	Transient with .01µF cap	Transient with 14v TransGuard
Geared motor at turn off	60V	32V	48V	30V
Geared motor during running	12V pk-pk	4.0V pk-pk	4.0V pk-pk	4.0V pk-pk

Fig. 1. Geared Motor Transient at Turnoff without protection 60 V Gear Motor 20 V/Division

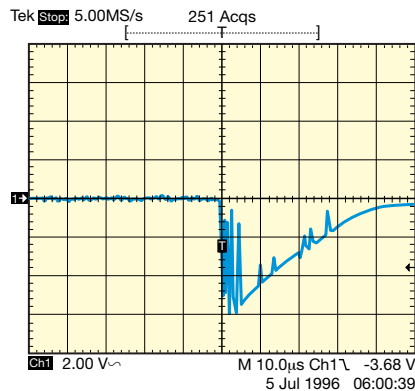

Fig. 1A. Geared Motor Transient at Turnoff with 14 V TransGuard 30 V 10 V/Division

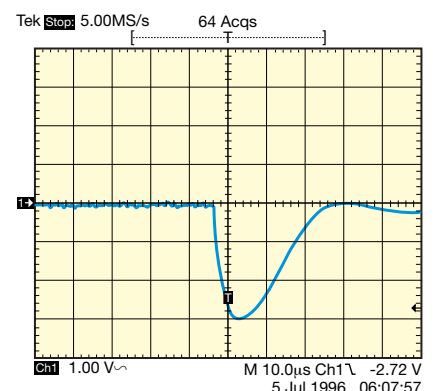

Fig. 2. Geared Motor Running noise without protection 12 V pk-pk 2 V/Division

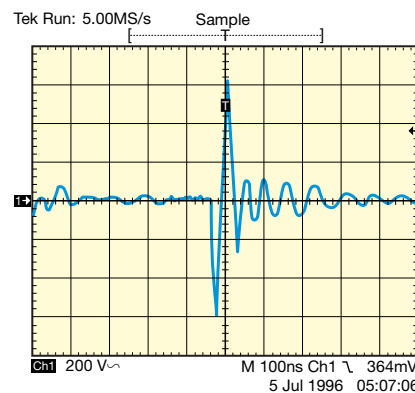
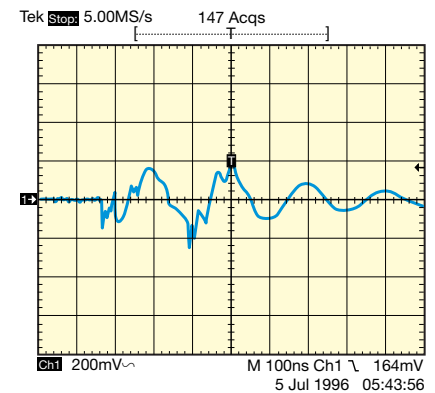

Fig. 2A. Geared Motor Running with 14 V TransGuard 4 V pk-pk 2 V/Division



TransGuard[®]

AVX Multilayer Ceramic Transient Voltage Suppressors

Application Notes: Motor and Relay Application Study



BISCUT FAN

The Comair 24V and 12V biscut fans were tested only for transients at turn off. Results of those tests are shown in the table at the right (as well as slope traces 3, 3A, 4, 4A).

Motor Type	Transient without Protection	Transient with .1 μ F cap	Transient with .01 μ F cap	Transient with TransGuard
24V Fan	165V	120V	140V	65V ⁽¹⁾
12V Fan	60V	52V	64V	30V ⁽²⁾

⁽¹⁾ VA100030D650 TransGuard / ⁽²⁾ VA100014D300 TransGuard

Fig. 3. 24 V Biscut Fan without protection
165 V Biscut 50 V/Division

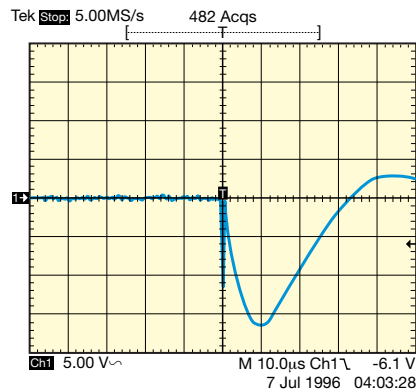

Fig. 3A. 24 V Biscut Fan with 30 V TransGuard
65 V 50 V/Division

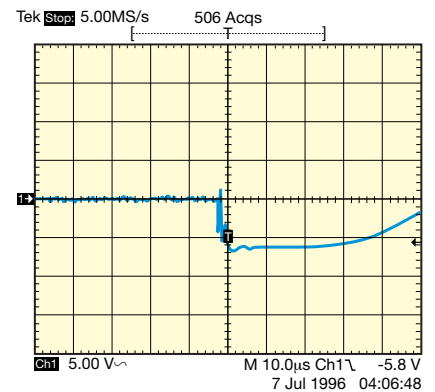

Fig. 4. 12 V Biscut Fan without protection
60 V 20 V/Division

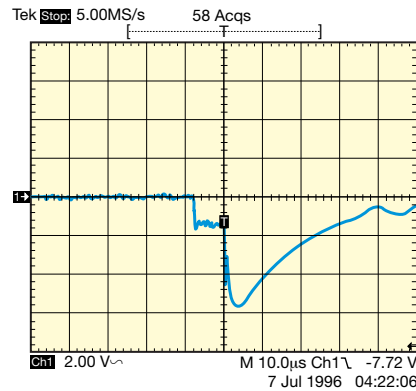
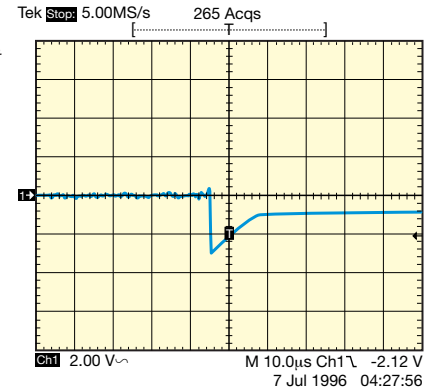

Fig. 4A. 12 V Biscut Fan with 14 V TransGuard
30 V 20 V/Division



RELAYS

The 12V and 24V relays were tested only for transients at turn off. The results of those tests are shown in the table at the right (as well as scope traces 5, 5A, 6, 6A).

Relay Type	Transient without Protection	Transient with .1 μ F cap	Transient with .01 μ F cap	Transient with TransGuard
24V	44V	24V	28V	28V ⁽³⁾
12V	105V	63V	100V	30V ⁽⁴⁾

⁽³⁾ VA100026D580 TransGuard / ⁽⁴⁾ VA100014D300 TransGuard

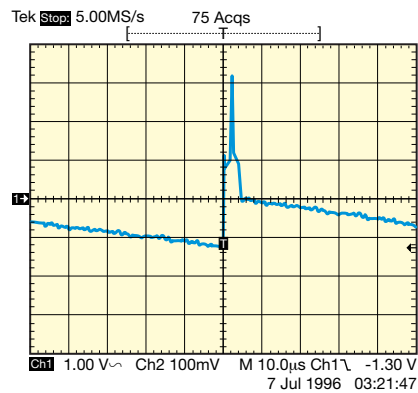
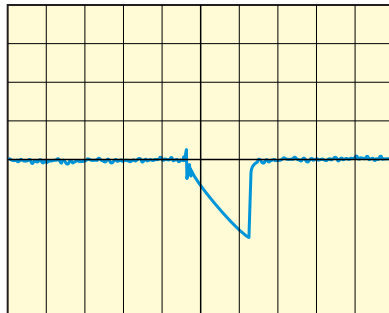
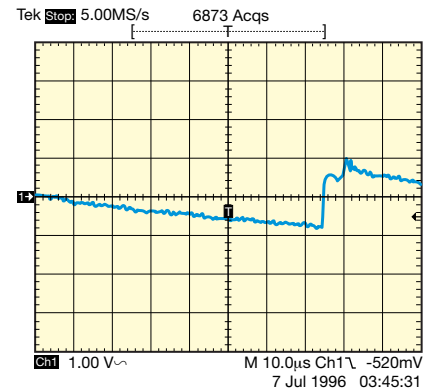

Fig. 5A. 24 V Relay Transient with 26 V TransGuard 10 V/Division



CONCLUSIONS

TransGuards can clamp the wide range of voltages coming from small/medium motors and relays due to inductive discharge. In addition, TransGuards capacitance can help reduce EMI/RFI. Proper selection of the TransGuards voltage is critical to clamping efficiency and correct circuit operation.

The current trend in automobiles is towards increased performance, comfort and efficiency. To achieve these goals, automobile companies are incorporating an ever increasing array of electronics into cars. As the electronic content within cars increases, auto manufacturers are utilizing multiplex bus designs to network all the sensors to a central point (usually the engine control unit [ECU]). Multiplex lines save wiring harness weight and decrease the harness' complexity, while allowing higher communication speeds. However, the multiplex structure tends to increase the occurrence and severity of Electromagnetic Interference (EMC) and Electrostatic Discharge (ESD).

Multilayer varistors (MLVs) are a single component solution for auto manufacturers to utilize on multiplex nodes to eliminate both ESD and EMC problems. MLVs also offer improved reliability rates (FIT rates <1 failure/billion hours) and smaller designs over traditional diode protection schemes.

TYPICAL MUX NODE APPLICATION

There are a variety of SAE recommended practices for vehicle multiplexing (J-1850, J-1939, J-1708, J-1587, CAN). Given the number of multiplexing specifications, it is easy to understand that bus complexity will vary considerably.

Each node has an interface circuit which typically consists of a terminating resistor (or sometimes a series limiting resistor), back to back Zener diodes (for over voltage protection) and an EMC capacitor. Such a method is compared to that of a multilayer varistor in Figure 1.

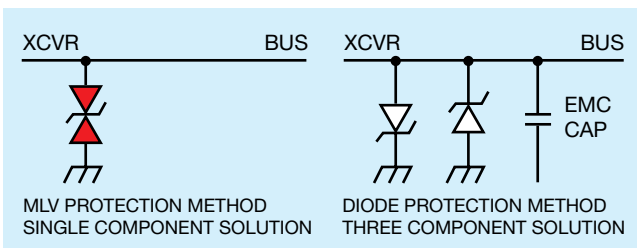

Figure 1. Comparison of past node protection methods to MLV node protection methods.

To more clearly understand the functional structure of a MLV, see the equivalent electrical model shown in Figure 2.

- MULTIPLE ELECTRODES YIELD A CAPACITANCE
- THE CAPACITANCE CAN BE USED IN DECOUPLING
- CAPACITANCE CAN BE SELECTED FROM 30pF TO 4700pF

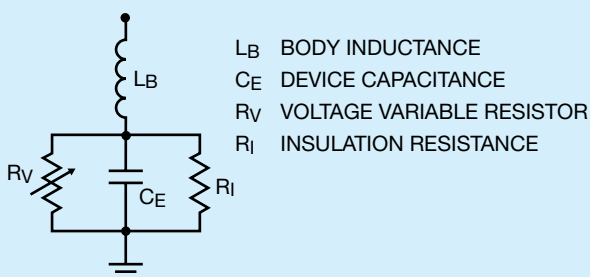

Figure 2. TransGuard Equivalent Model.

As the schematic in Figure 1 illustrates, the implementation of MLV protection methods greatly simplifies circuit layout, saves PCB space and improves system reliability. The MLV offers many additional electrical improvements over the Zener/passive schemes. Among those advantages are higher multiple strike capability, faster turn on time and larger transient overstrike capability. Further clarification on the types of varistors compared to the performance of Zener diodes follows.

CONSTRUCTION AND PHYSICAL COMPARISON

The construction of Zinc Oxide (ZnO) varistors is a well known, relatively straightforward process in which ZnO grains are doped with cobalt, bismuth, manganese and other oxides. The resulting grains have a Schottky barrier at the grain interface and a typical grain breakdown voltage (V_b) of approximately 3.6V per grain.

Currently, there are two types of varistors. Single layer varistors (SLVs) – an older technology referred to as “pressed pill,” typically are larger, radial leaded components designed to handle significant power. Multilayer varistors (MLVs) are a relatively new technology packaged in true EIA SMT case sizes.

Beyond the ZnO material system and grain breakdown similarity, MLVs and SLVs have little in common. That is, to design a low voltage SLV, the grains must be grown as large as possible to achieve a physically large enough part to be handled in the manufacturing process. Typically it is very difficult to obtain a consistent grain size in a low voltage SLV process.

The electrical performance of SLV is affected by inconsistent grain size in two ways. First, low voltage SLVs often exhibit an inconsistent V_b and leakage current (I_L) from device to device within a particular manufacturing lot of a given rating. This contributes to early high voltage repetitive strike wear out.

Secondly, SLVs with similar voltage and energy ratings as MLVs typically exhibit a lower peak current capability due in part to increased resistance of the long current path of the large grains. This contributes to early repetitive high current wear out.

At higher voltages, the grain size variations within SLVs play a much smaller percentage role in V_b and leakage current values. As a result, SLVs are the most efficient cost effective way to suppress transients in high voltages (e.g., 115 VAC, 220 VAC).

MLV MANUFACTURE

The construction of a MLV was made possible by employing a variety of advanced multilayer chip capacitors (MLCC) manufacturing schemes coupled with a variety of novel and proprietary ZnO manufacturing steps. In the MLCC process, thin dielectrics are commonly employed to obtain very large capacitance values. It is that capability to design and manufacture multilayer structures with dielectric thicknesses of ≤ 1 mil that allows MLVs to be easily made with operating/working voltages (V_{wm}) as low as 3.3V (for use in next generation silicon devices).

Once a particular working voltage has been determined (by altering the ZnO dielectric thickness), the multilayer varistor's transient energy capability is determined by the number of layers of dielectric and electrodes. It is, therefore, generally easy to control the grain size and uniformity within a MLV due to the relative simplicity of this process.

MLVs exhibit capacitance due to their multiple electrode design and the fact that ZnO is a ceramic dielectric. This capacitance can be utilized with the device's series inductance to provide a filter to help limit EMI/RFI. The equivalent model of a MLV is shown in Figure 2.

MLVs are primarily used as transient voltage suppressors. In their "on" state, they act as a back-to-back Zener, diverting to ground any excess, unwanted energy above their clamping voltage. In their "off" state, they act as an EMC capacitor (capacitance can be minimized for high speed applications). A single MLV, therefore, can replace the diode, capacitor and resistor array on multiplex node applications.

Any TVS will see a large number of transient strikes over its lifetime. These transient strikes will result from different events such as well known ESD HBM, IC MM, alternator field decay, load dump models and uncontrolled random events. It is because of the repetitive strikes that all TVS suppressors should be tested for multiple strike capability. Typically, a TVS will fail due to high voltage, high current or over-energy strikes.

High voltage repetitive strikes are best represented by IEC 61000-4-2 8kV waveforms. MLVs demonstrate a greatly superior capability to withstand repetitive ESD high voltage discharge without degradation.

High current repetitive strikes are represented by 8x20 μ s 150A waveforms. A comparison between MLVs, SLVs and SiTVS is shown in Figures 3A, B, C respectively.

SILICON TVS MANUFACTURE

The construction of a silicon TVS departs dramatically from that of either single layer varistor or multilayer varistor construction. Devices are generally produced as Zener diodes with the exception that a larger junction area is designed into the parts and additional testing was likely performed. After the silicon die is processed in accordance to standard semi-conductor manufacturing practice, the TVS die is connected to a heavy metal lead frame and molded into axial and surface mount (SMT) configuration.

MLVs COMPARED TO DIODES

The response time for a silicon diode die is truly sub-nanosecond. The lead frame into which the die is placed and the wire bonds used for die connections introduce a significant amount of inductance. The large inductance of this packaging causes a series impedance that slows the response time of SiTVS devices. A best case response time of 8nS on SOT23 and a 1.5nS to 5nS response time on SMB and SMC products respectively are rather typical. MLVs turn on time is <7nS. MLVs turn on time is faster than SiTVS and that fast turn on time diverts more energy and current away from the IC than any other protection device available.

CONCLUSION

The technology to manufacture MLVs exists and allows the manufacture of miniature SMT surge suppressors. MLVs do not have the wear out failure mode of first generation (single layer) varistors. In fact, MLVs exhibit better reliability numbers than that of TVS diodes. MLVs are a viable protection device for auto multiplex bus applications.

Written by Ron Demcko

Originally printed in EDN PRODUCTS EDITION December 1997 by CAHNERS PUBLISHING COMPANY

150 AMP Current Repetitive Strike Comparison

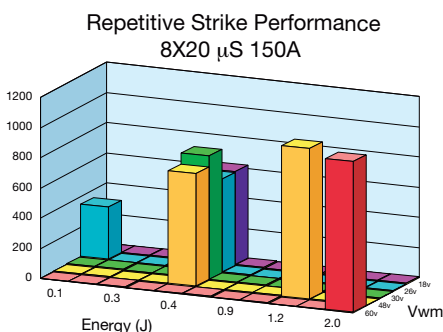

Figure 3A. Multilayer Varistor.

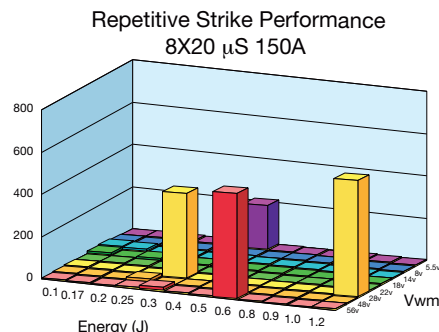

Figure 3B. Single Layer Varistor.

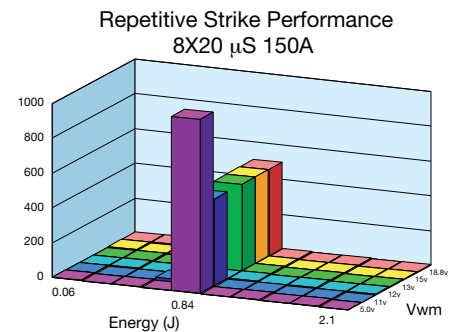

Figure 3C. Silicon TVS.

AVX *TransGuard*[®]

PACKAGING

- Chips
- Axial Leads

Paper Carrier Configuration



8mm Tape Only

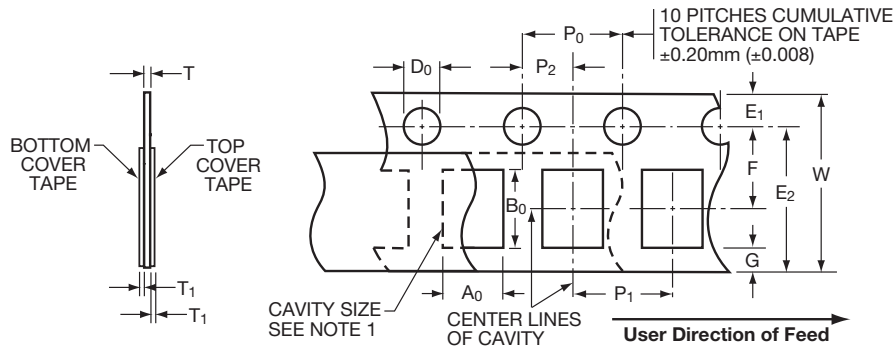

8mm Paper Tape Metric Dimensions Will Govern

CONSTANT DIMENSIONS

Tape Size	D ₀	E	P ₀	P ₂	T ₁	G. Min.	R Min.
8mm	1.50 ^{+0.10} _{-0.0} (0.059 ^{+0.004} _{-0.0})	1.75 ± 0.10 (0.069 ± 0.004)	4.00 ± 0.10 (0.157 ± 0.004)	2.00 ± 0.05 (0.079 ± 0.002)	0.10 (0.004) Max.	0.75 (0.030) Min.	25.0 (0.984) See Note 2 Min.

VARIABLE DIMENSIONS

Tape Size	P ₁ See Note 4	E ₂ Min.	F	W	A ₀ B ₀	T
8mm	4.00 ± 0.10 (0.157 ± 0.004)	6.25 (0.246)	3.50 ± 0.05 (0.138 ± 0.002)	8.00 ^{+0.08} _{-0.08} (0.315 ^{+0.012} _{-0.012})	See Note 1	1.10mm (0.043) Max. for Paper Base Tape and 1.60mm (0.063) Max. for Non-Paper Base Compositions

NOTES:

- The cavity defined by A₀, B₀, and T shall be configured to provide sufficient clearance surrounding the component so that:
 - the component does not protrude beyond either surface of the carrier tape;
 - the component can be removed from the cavity in a vertical direction without mechanical restriction after the top cover tape has been removed;
 - rotation of the component is limited to 20° maximum (see Sketches A & B);
 - lateral movement of the component is restricted to 0.5mm maximum (see Sketch C).

- Tape with or without components shall pass around radius "R" without damage.
- Bar code labeling (if required) shall be on the side of the reel opposite the sprocket holes. Refer to EIA-556.
- If P₁ = 2.0mm, the tape may not properly index in all tape feeders.

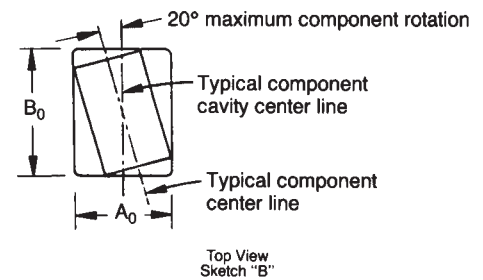
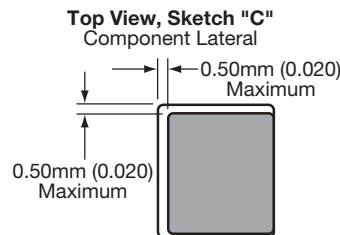
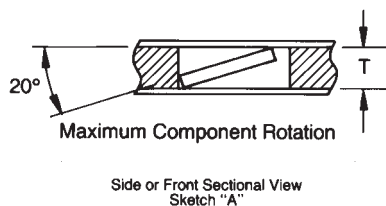

Bar Code Labeling Standard

AVX bar code labeling is available and follows latest version of EIA-556



Embossed Carrier Configuration



8 & 12mm Tape Only

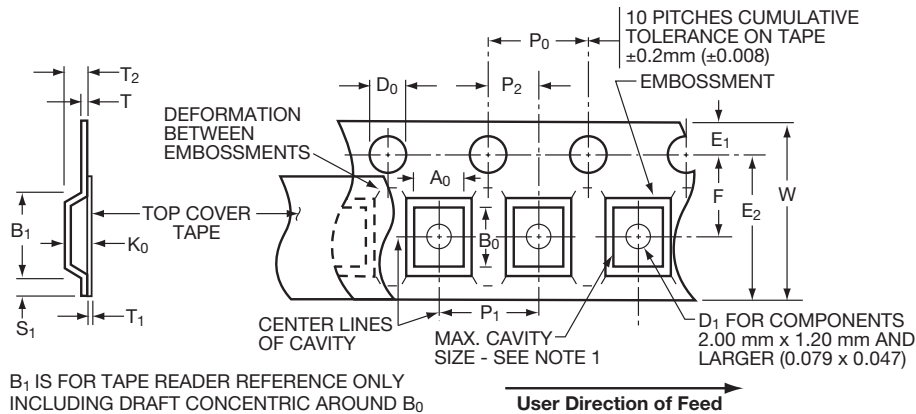

B₁ IS FOR TAPE READER REFERENCE ONLY INCLUDING DRAFT CONCENTRIC AROUND B₀

8 & 12mm Embossed Tape Metric Dimensions Will Govern

CONSTANT DIMENSIONS

mm (inches)

Tape Size	D ₀	E	P ₀	P ₂	S ₁ Min.	T Max.	T ₁
8mm and 12mm	1.50 ^{+0.10} _{-0.0} (0.059 ^{+0.004} _{-0.0})	1.75 ± 0.10 (0.069 ± 0.004)	4.0 ± 0.10 (0.157 ± 0.004)	2.0 ± 0.05 (0.079 ± 0.002)	0.60 (0.024)	0.60 (0.024)	0.10 (0.004) Max.

VARIABLE DIMENSIONS

mm (inches)

Tape Size	B ₁ Max.	D ₁ Min.	E ₂ Min.	F	P ₁ See Note 5	R Min. See Note 2	T ₂	W Max.	A ₀ B ₀ K ₀
8mm	4.35 (0.171)	1.00 (0.039)	6.25 (0.246)	3.50 ± 0.05 (0.138 ± 0.002)	4.00 ± 0.10 (0.157 ± 0.004)	25.0 (0.984)	2.50 Max. (0.098)	8.30 (0.327)	See Note 1
12mm	8.20 (0.323)	1.50 (0.059)	10.25 (0.404)	5.50 ± 0.05 (0.217 ± 0.002)	4.00 ± 0.10 (0.157 ± 0.004)	30.0 (1.181)	6.50 Max. (0.256)	12.3 (0.484)	See Note 1

NOTES:

- The cavity defined by A₀, B₀, and K₀ shall be configured to provide the following:
 - the component does not protrude beyond the sealing plane of the cover tape.
 - the component can be removed from the cavity in a vertical direction without mechanical restriction, after the cover tape has been removed.
 - rotation of the component is limited to 20° maximum (see Sketches D & E).
 - lateral movement of the component is restricted to 0.5mm maximum (see Sketch F).
- Tape with or without components shall pass around radius "R" without damage.
- Bar code labeling (if required) shall be on the side of the reel opposite the round sprocket holes. Refer to EIA-556.
- B₁ dimension is a reference dimension for tape feeder clearance only.
- If P₁ = 2.0mm, the tape may not properly index in all tape feeders.

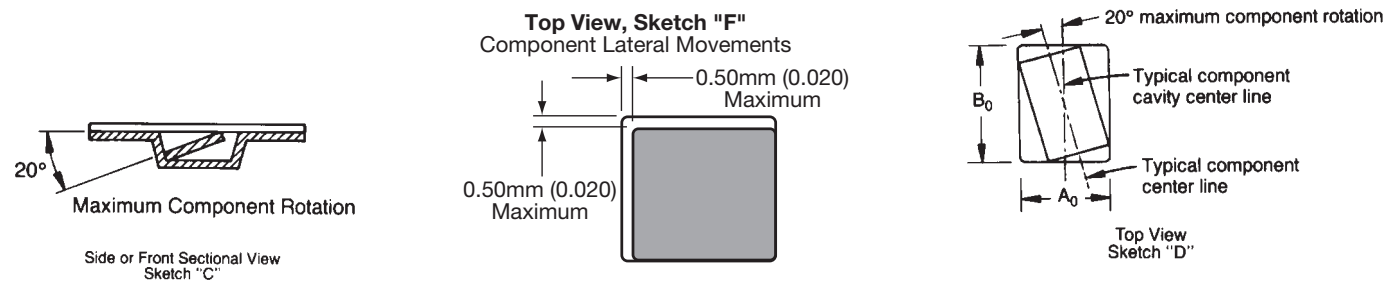

Packaging of Chip Components



Automatic Insertion Packaging

REEL DIMENSIONS

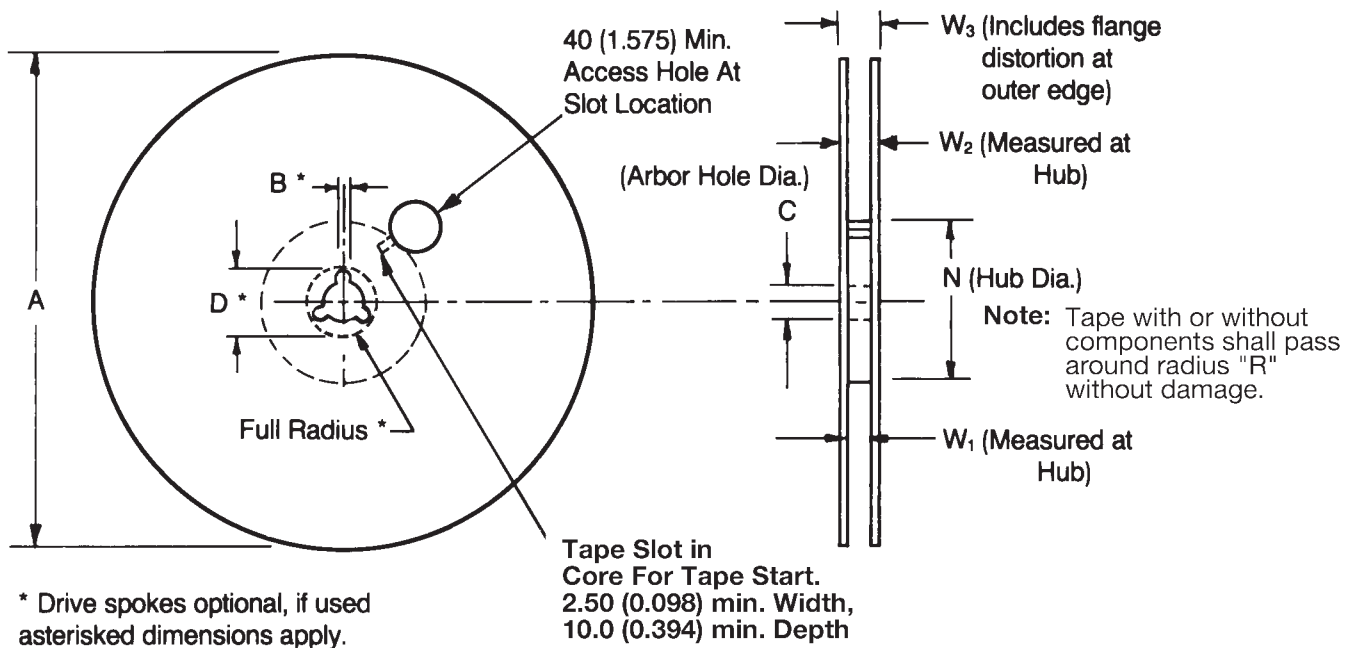

mm (inches)

Tape Size	A Max.	B* Min.	C	D* Min.	N Min.	W ₁	W ₂ Max.	W ₃
8mm	330 (12.992)	1.5 (0.059)	13.0 ^{+0.50} _{-0.20} (0.512 ^{+0.020} _{-0.008})	20.2 (0.795)	50.0 (1.969)	8.40 ^{+1.5} _{-0.0} (0.331 ^{+0.059} _{-0.0})	14.4 (0.567)	7.90 Min. (0.311)
12mm						12.4 ^{+2.0} _{-0.0} (0.488 ^{+0.079} _{-0.0})		11.9 Min. (0.469)
								10.9 Max. (0.429)
								15.4 Max. (0.607)

Metric dimensions will govern.
English measurements rounded and for reference only.

PACKAGING - AXIAL LEADS / TAPE AND REEL

CLASS I / RS-296	
A.	5mm ± 0.5mm (0.200" ± 0.020")
B*	52.4mm ± 1.5mm (2.063" ± 0.059")
C.	6.35mm ± 0.4mm (0.250" ± 0.016")
D ¹ -D ² .	1.4mm (0.055" MAX.)
E.	1.2mm (0.047" MAX.)
F.	1.6mm (0.063" MAX.)
G.	356mm (14.00" MAX.)
H.	76mm (3.000")
I.	25.4mm (1.000")
J.	84mm (3.300")
K.	70mm (2.750")

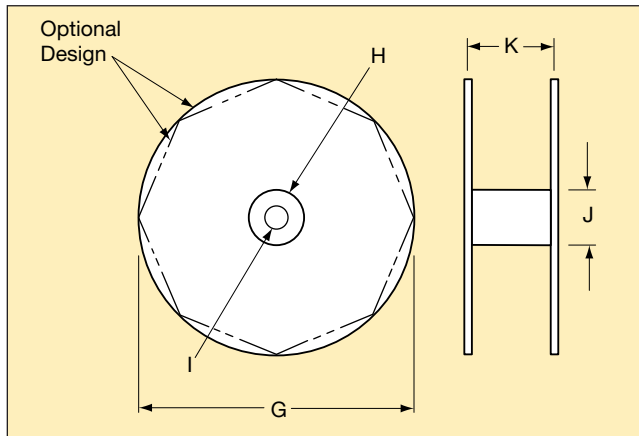
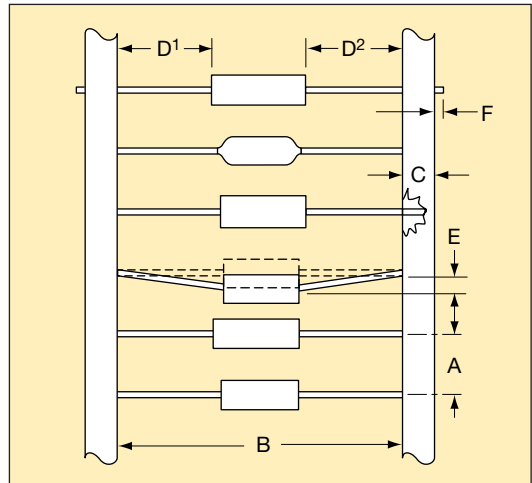

Leader Tape: 300mm min. (12")

Splicing: Tape Only

Missing Parts: 0.25% of component count max.-
No consecutive missing parts

USA

AVX Myrtle Beach, SC
Corporate Offices
Tel: 843-448-9411
FAX: 843-448-1943

AVX North Central, IN
Tel: 317-848-7153
FAX: 317-844-9314

AVX Southwest, AZ
Tel: 602-678-0384
FAX: 602-678-0385

AVX Southeast, GA
Tel: 404-608-8151
FAX: 770-972-0766

AVX Northwest, WA
Tel: 360-699-8746
FAX: 360-699-8751

AVX Mid/Pacific, CA
Tel: 510-661-4100
FAX: 510-661-4101

AVX South Central, TX
Tel: 972-669-1223
FAX: 972-669-2090

AVX Canada
Tel: 905-238-3151
FAX: 905-238-0319

EUROPE

AVX Limited, England
European Headquarters
Tel: ++44 (0) 1252-770000
FAX: ++44 (0) 1252-770001

AVX/ELCO, England
Tel: ++44 (0) 1638-675000
FAX: ++44 (0) 1638-675002

AVX S.A., France
Tel: ++33 (1) 69-18-46-00
FAX: ++33 (1) 69-28-73-87

AVX GmbH, Germany
Tel: ++49 (0) 8131-9004-0
FAX: ++49 (0) 8131-9004-44

AVX srl, Italy
Tel: ++390 (0)2 614-571
FAX: ++390 (0)2 614-2576

AVX Czech Republic
Tel: ++420 465-358-111
FAX: ++420 465-323-010

ASIA-PACIFIC

AVX/Kyocera, Singapore
Asia-Pacific Headquarters
Tel: (65) 6286-7555
FAX: (65) 6488-9880

AVX/Kyocera, Hong Kong
Tel: (852) 2-363-3303
FAX: (852) 2-765-8185

AVX/Kyocera, Korea
Tel: (82) 2-785-6504
FAX: (82) 2-784-5411

AVX/Kyocera, Taiwan
Tel: (886) 2-2698-8778
FAX: (886) 2-2698-8777

AVX/Kyocera, Malaysia
Tel: (60) 4-228-1190
FAX: (60) 4-228-1196

Elco, Japan
Tel: 045-943-2906/7
FAX: 045-943-2910

Kyocera, Japan - AVX
Tel: (81) 75-604-3426
FAX: (81) 75-604-3425

Kyocera, Japan - KDP
Tel: (81) 75-604-3424
FAX: (81) 75-604-3425

AVX/Kyocera, Shanghai, China
Tel: 86-21 6341 0300
FAX: 86-21 6341 0330

AVX/Kyocera, Tianjin, China
Tel: 86-22 2576 0098
FAX: 86-22 2576 0096

Contact:

